

8Gb/s SFP Optical Transceiver Module

SPP5100SX-GL

(2/4/8GFC-SW, 850nm VCSEL, PIN-PD)

Features

- ◆ 2/4/8Gb/s Serial Optical Interface
 - High quality and reliability optical device and sub-assemblies
 - 850nm VCSEL laser for up to 135m over Multi Mode Fiber
 - High sensitivity PIN photodiode and TIA
- ◆ SFP+ MSA Compliant
 - Easy supply management for hot pluggability
 - Duplex LC Receptacle
 - SFP Mechanical Interface for easy removal
 - SFI High Speed Electrical Interface
 - 2-wire interface for management and diagnostic monitor
 - Tx_Disable, Rx_LOS and Rate select functions
- ◆ Protocol
 - ANSI INCITS FC-P1-4 standards, Fiber Channel Physical Interface, Rev 4.00
- ◆ RoHS6 compliant
- ◆ Low Power Consumption
 - Single 3.3V power supply



Applications

- ◆ 2/4/8GFC switches and routers
- ◆ 2/4/8GFC Storage
- ◆ Inter Rack Connection
- ◆ Other high speed data connections

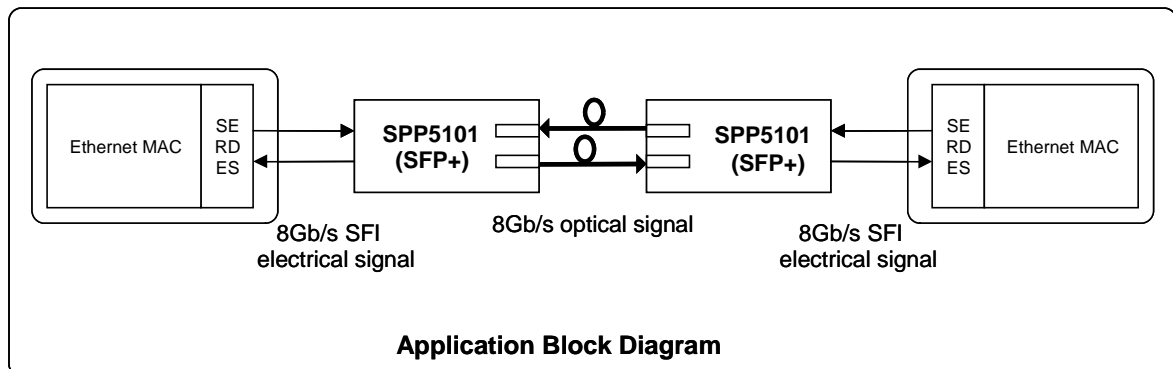

1. General Description

The SPP5100SX-GL is a very compact 8Gb/s optical transceiver module for serial optical communication applications at multi-rate of 2/4/8Gb/s. The SPP5100SX-GL converts a 8Gb/s serial electrical data stream to 8Gb/s optical output signal and a 8Gb/s optical input signal to 8Gb/s serial electrical data streams. The high speed 8Gb/s electrical interface is fully compliant with SFI specification.

The SPP5100SX-GL is designed for 8G Fiber Channel (8.5Gb/s) applications. The high performance 850nm VCSEL transmitter and high sensitivity PIN receiver provide superior performance for Ethernet applications at up to 150m links.

The fully SFP compliant form factor provides hot pluggability, easy optical port upgrades and low EMI emission.

Table 1. Fiber compliance

SFP+ type	Wavelength [nm]	Cable Type	Core Size (micron)	Modal Bandwidth [MHz/km]	Cable distance			
8GFC-SW	850	MMF	62.5	200/500	21m(OM1)			
800-M6-SN-S								
800-M5-SN-S						50.0	500/500	50m(OM2)
800-M5E-SN-I						50.0	1500/500	150m(OM3)
400-M6-SN-I						62.5	200/500	70m(OM1)
400-M5-SN-I						50.0	500/500	150m(OM2)
400-M5E-SN-I						50.0	1500/500	380m(OM3)
200-M6-SN-S						62.5	200/500	150m(OM1)
200-M5-SN-S						50.0	500/500	300m(OM2)
200-M5E-SN-I						50.0	1500/500	500m(OM3)

2. Functional Description

The SPP5100SX-GL contains a duplex LC connector for the optical interface and a 20-pin connector for the electrical interface. Figure 2.1 shows the functional block diagram of SPP5100SX-GL SFP Transceiver.

Transmitter Operation

The transceiver module receives 8Gb/s electrical data and transmits the data as an optical signal.

The transmitter output can be turned off by Tx disable signal, TX_DIS pin. When TX_DIS is asserted High, Transmitter is turned off.

Receiver Operation

The received optical signal is converted to serial electrical data signal.

The RX_LOS signal indicates insufficient optical power for reliable signal reception at the receiver.

Management Interface

A 2-wire interface (SCL, SDA) is used for serial ID, digital diagnostics and other control /monitor functions.

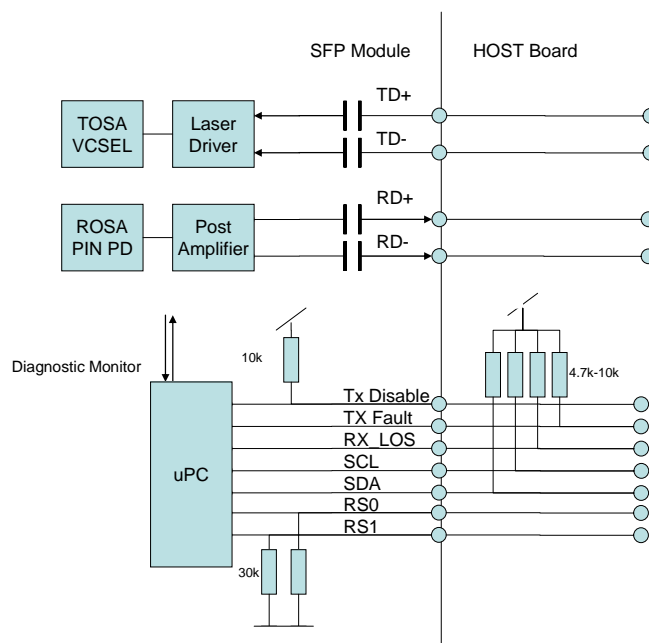

Figure 2.1. Functional Block Diagram

3. Package Dimensions

Figure 3.1. shows the package dimensions of SPP5100SX-GL. SPP5100SX-GL is designed to be compliant with SFP MSA specification. Package dimensions are specified in SFF-8432.

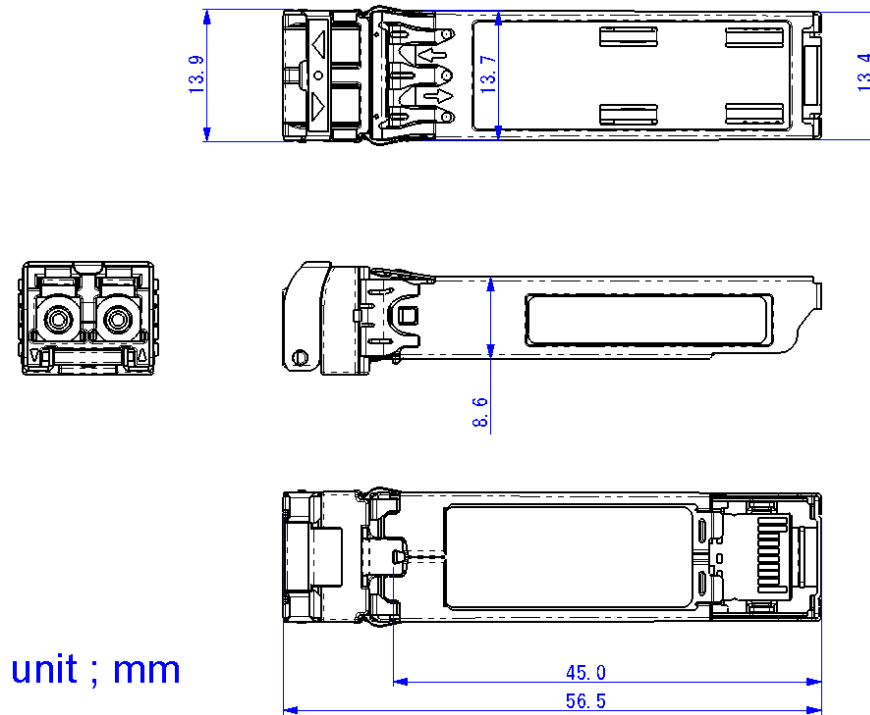

Figure 3.1. Package dimensions

4. Pin Assignment and Pin Description

4.1. SFP Transceiver Electrical Pad Layout

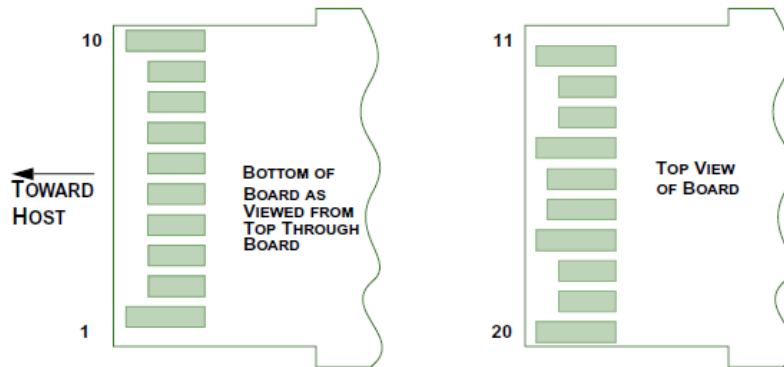

Figure 4.1. SFP Transceiver Electrical Pad Layout

4.2. Host PCB SFP Pinout

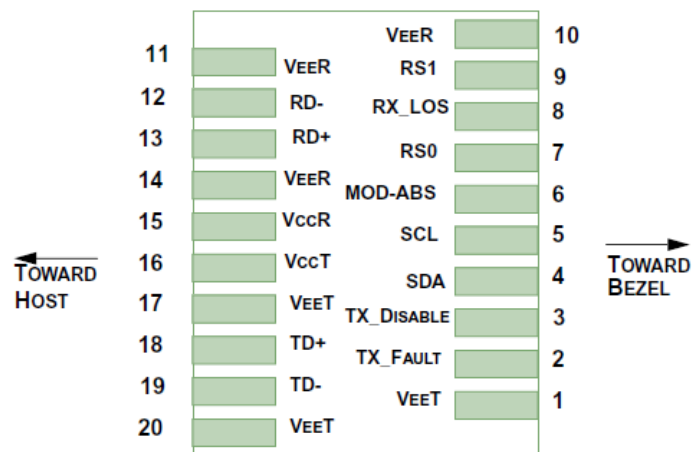

Figure 4.2. Host PCB SFP Pinout

4.3. Pin Descriptions

Table 4.3. Pin Description

Pin#	Name	Logic	Description	Power Sequence Order	Note
1	VeeT		Module Transmitter Ground	1 st	1
2	Tx_Fault	LVTTL-O	Module Transmitter Fault	3 rd	2
3	Tx_Disable	LVTTL-I	Transmitter Disable, Turns off transmitter laser output	3 rd	3
4	SDA	LVTTL-I/O	2 Wire Serial Interface Data Line(Same as MOD-DEF2 as defined in the INF-8074i)	3 rd	
5	SCL	LVTTL-I/O	2 Wire Serial Interface Data Line(Same as MOD-DEF1 as defined in the INF-8074i)	3 rd	
6	MOD_ABS		Module Absent, connected to VeeT or VeeR in the module	3 rd	2
7	RS0	LVTTL-I	Rate Select 0 (not functional)	3 rd	
8	RX_LOS	LVTTL-O	Receiver Loss of Signal Indication	3 rd	2
9	RS1	LVTTL-I	Rate Select 1 (high input for >4.25GBd)	3 rd	
10	VeeR		Module Receiver Ground	1 st	1
11	VeeR		Module Receiver Ground	1 st	1
12	RD-	CML-O	Receiver Inverted Data Output	3 rd	
13	RD+	CML-O	Receiver Non-Inverted Data Output	3 rd	
14	VeeR		Module Receiver Ground	1 st	1
15	VccR		Module Receiver 3.3V Supply	2 nd	
16	VccT		Module Transmitter Ground	2 nd	
17	VeeT		Module Transmitter Ground	1 st	1
18	TD+	CML-I	Transmitter Non-Inverted Data Input	3 rd	
19	TD-	CML-I	Transmitter Inverted Data Input	3 rd	
20	VeeT		Module Transmitter Ground	1 st	1

Note

- 1: Module ground pins are isolated from the module case and chassis ground within the module.
- 2: Shall be pulled up with 4.7k to 10k ohm to a voltage between 3.15V and 3.45V on the host board.
- 3: Shall be pulled up with 4.7k to 10k ohm to VccT in the module.

5. Absolute Maximum Ratings and Recommended Operating Conditions

Table 5.1. Absolute Maximum Ratings

Parameter	Symbol	Min	Max	Unit	Note
Storage Temperature	Tst	-40	85	degC	
Relative Humidity (non-condensation)	RH	-	85	%	
Operating Case Temperature	Topc	0	70	degC	1
Supply Voltage	VccR/VccT	-0.5	3.6	V	
Voltage on LVTTTL Input	Vilvttl	-0.5	VCC3+0.5	V	
LVTTTL Output Current	Iolvttl	-	15	mA	
Voltage on Open Collector Output	Voco	0	6	V	
Receiver Input Optical Power(Average)	Mip	-	0	dBm	

Note:

1: Ta is typically -10 to 60degC with 1.5m/s airflow.

Table 5.2. Recommended Operating Conditions and Supply Requirements

Parameter	Symbol	Min	Max	Unit	Note
Operating Case Temperature	Topc	0	70	degC	
Relative Humidity(non-condensing)	Rhop	-	85	%	
Power Supply Voltage	VccR/VccT	3.135	3.465	V	
Total Power Consumption	Pd	-	1.0	W	

6. Electrical Interface

6.1. High Speed Electrical Interface

SFI Application Reference model

Figure 6.1.1. shows the high speed electrical interface (SFI) compliance points.

SFI electrical interface is specified for each compliance point in the SFP MSA specification.

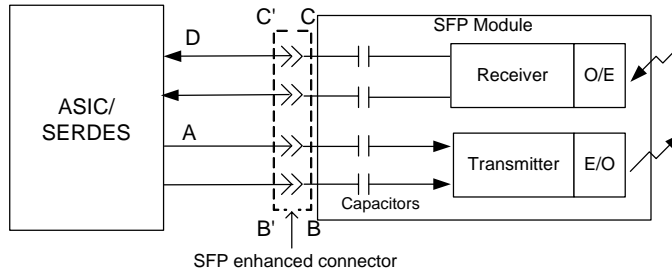

Figure 6.1.1. SFI Application Reference Model

SFI Module Transmitter Input Electrical Interface Specification at B' and Calibrated B''

Table 6.1.1. SFI Transmitter Input Electrical Specification at B'

Parameter B'	Symbol	Condition	Min	Typ.	Max.	Unit
Single Ended Output Voltage Tolerance		Referenced to VeeT	-0.3		4.0	V
AC common Input S-parameter			15			mV
Differential Input S-parameter (note 1)	SDD11	0.01-1GHz			-12	dB
		1-11.1GHz			Note 2	dB
Reflected Differential to Common Mode Conversion (note 3)	SCD11	0.01-11.1GHz			-10	dB

Note 1. Reference differential impedance is 100 ohm

2. Return Loss given by equation $SDD11(dB) = -12.9 + 0.9 * (f/1e9)$, with f in GHz

3. Common mode reference impedance is 25 ohm

Table 6.1.2. SFI Transmitter Input Electrical Specification at B''

Parameter B''	Symbol	Condition	Min	Typ.	Max.	Unit
AC Common Mode Voltage		Note 1			15	MV
Total Jitter	TJ	Note 1		0.28		UIpp
Data Dependant Jitter	DDJ			0.10		UIpp
Pulse Width Shrinkage Jitter	DDPWS			0.055		UIpp
Uncorrelated Jitter	UJ	Note 2		0.023		UIrms
Eye Mask Figure 6.1.2	X1			0.14		UI
	X2				0.35	UI
	Y1			90		mV
	Y2				350	mV

Note 1. Re The tester is not expected to generate this common mode voltage however its output must not exceed this value.

2. It is not possible to have the worst UJ and DDJ simultaneously and meet the TJ specifications if the UJ is all Gaussian.

SFI Module Receiver Output Electrical Interface Specification at C'

Table 6.1.3. SFI Receiver Output Electrical Specification at C'

Parameter – C'	Symbol	Conditions	Min	Typ	Max	Units
Crosstalk source rise/fall time (20% to 80%)	Tr, Tf	Note 1		34		ps
Crosstalk Source Amplitude Differential (p-p)		Note 2		700		mV
Termination Mismatch at 1 MHz	ΔZ_M				5	%
Single Ended Output Voltage Tolerance			-0.3		4.0	V
Output AC Common Mode Voltage					7.5	mV (RMS)
Differential Output S-parameter (Note 3)	SDD22	0.01-1GHz			-12	dB
		1-11.1GHz			Note 4	dB
Common Mode Output Reflection Coefficient (Note 5)	SCC22	0.01-2.5GHz			-6	dB
		2.5-11.1GHz			-3	dB

Note1 : Measured with OMA test pattern. Use of five 1's and four 0's sequence in the PRBS 9 is an

acceptable alternative.

2 : For dRNx compliance test condition. Crosstalk is not used for dRN.

3 : Reference differential impedance is 100 ohm.

4 : Differential Output S-parameter given by equation $SDD11(dB) = -12.9 + 0.9 \cdot (f/1e9)$, with f in GHz.

5 : Common mode reference impedance is 25 ohm.

Table 6.1.4. SFP+ Limiting Output Jitter and Eye Mask Specification at C'

Parameter – C'	Symbol	Conditions	Min	Typ	Max	Units
Output rise/fall time (20% to 80%)	Tr, Tf	Note 1	28			ps
Total Jitter	TJ	Note 2			0.70	UIpp
Deterministic Jitter	DJ				0.42	UIpp
Eye Mask Figure 6.1.3	X1				0.35	UI
	Y1		150			mV
	Y2				425	mV

Note1 : Measured at B' with Host Compliance Board and Module Compliance Board pair and with OMA test pattern. Use of five 1's and four 0's sequence in the PRBS 9 is an acceptable alternative.

2 : The data pattern for the total jitter measurement is one of IEEE 802.3 CL52.9 Pattern 1, Pattern 3, or valid 64B/66B data traffic.

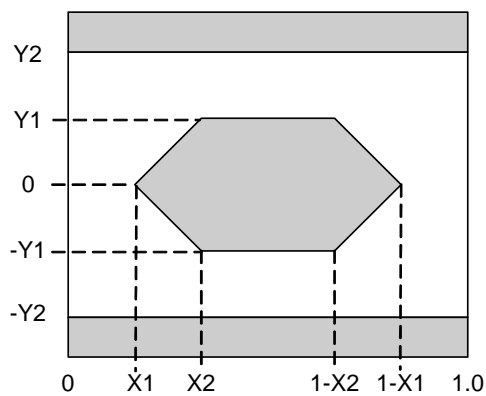

Figure 6.1.2.
Transmitter Input Eye Mask

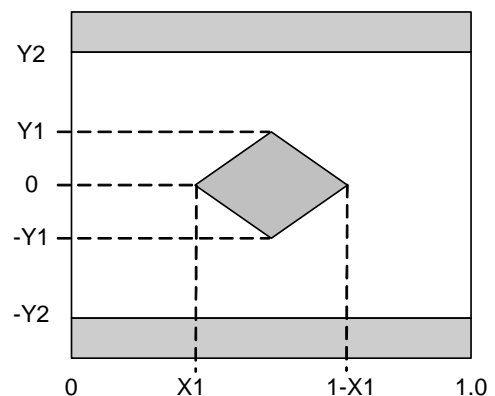

Figure 6.1.3.
Receiver Output Eye Mask

6.2. Low speed Electrical Interface

SPP5100SX-GL low speed interface is based on 2-wire interface. Management memory map is based on SFF-8472.

2-wire Electrical Specifications

Parameter	Symbol	Min	Max	Unit
Host 2-wire Vcc	Vcc_host	3.14	3.46	V
SCL and SDA	V _{OL}	0.0	0.40	V
	V _{OH}	Vcc_host-0.5	Vcc_host+0.3	V
SCL and SDA	V _{IL}	-0.3	VccT*0.3	V
	V _{IH}	VccT*0.7	VccT+0.5	V
Input current on the SCL and SDA contacts		-10	10	uA
Capacitance on SCL and SDA I/O contact			14	pF

2-wire Timing Specifications

Parameter	Symbol	Min	Max	Unit
Clock Frequency	f _{SCL}	0	400	kHz
Clock Pulse Width Low	t _{LOW}	1.3		us
Clock Pulse Width High	t _{HIGH}	0.6		us
Time bus free before new transmission can start	t _{BUF}	20		us
START Hold Time	t _{HD, STA}	0.6		us
START Set-up Time	t _{SU, STA}	0.6		us
Data In Hold Time	t _{HD, DAT}	0		us
Data In Set-up Time	t _{SU, DAT}	0.1		us
Input Rise Time (100kHz)	t _{R, 100}		1000	ns
Input Rise Time (400kHz)	t _{R, 400}		300	ns
Input Fall Time (100kHz)	t _{F, 100}		300	ns
Input Fall Time (400kHz)	t _{F, 400}		300	ns
STOP Set-up Time	t _{SU, STO}	0.6		us
Serial Interface Clock Holdoff “Clock Stretching”	t _{clock_hold}		500	us

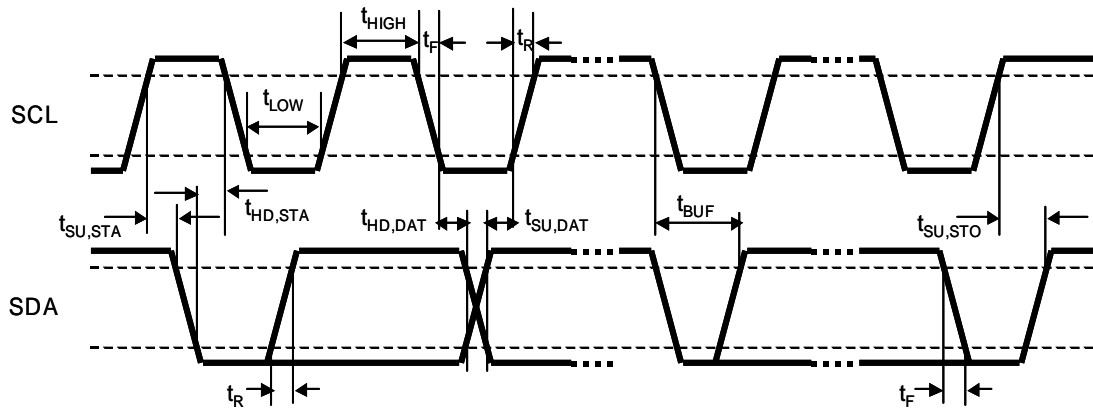

Figure 6.1.4. SFP+ Timing Diagram

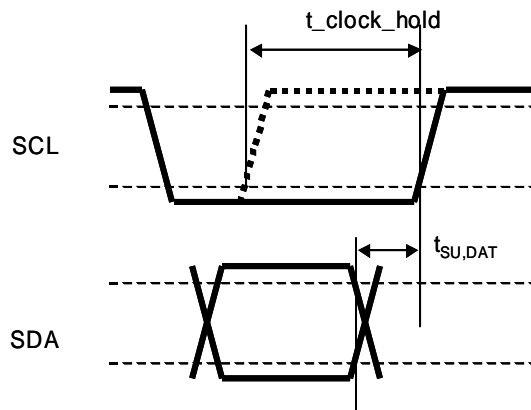

Figure 6.1.5. Detail of Clock Stretching

7. Optical Interface

Optical Interfaces of SPP5100SX-GL are defined in the FC-PI-4(Fiber Channel Physical Interface).

Optical Transmitter : 2/4/8GFC for OM1, OM2 and OM3

Parameter	Symbol	Min	Typ	Max	Unit
Signaling Speed, 8GFC			8.5		Gb/s
Signaling Speed, 4GFC			4.25		Gb/s
Signaling Speed, 2GFC		-	2.125		Gb/s
Signaling speed variation from nominal (max)		-100		+100	ppm
Center wavelength		840		860	nm
RMS spectral width, 8GFC	Lrms		0.65		nm
RMS spectral width, 4GFC			0.85 0.65(OM3)		nm
RMS spectral width, 2GFC			0.85		nm
Average launched power, 8GFC	Pave	-8.2		Note 1	dBm
Average launched power, 4GFC		-9		Note 1	dBm
Average launched power, 2GFC		-10		Note 1	dBm
OMA, 8GFC	Poma	0.302			mW
OMA, 4GFC		0.247			mW
OMA, 2GFC		0.196			mW
Rise/Fall time (20% to 80%), 8GFC	Tr/Tf			NA	ps
Rise/Fall time (20% to 80%), 4GFC				90	ps
Rise/Fall time (20% to 80%), 2GFC				150	ps
RIN OMA, 8GFC	RIN			-128	dB/Hz
RIN OMA, 4GFC				-118 -120(OM3)	dB/Hz
RIN OMA, 2GFC				-117	dB/Hz

Note 1: For details see sub-clause 8.2 of FC-PI-4 spec.

Note 2: Optical modulation amplitude values are peak-to-peak. See sub-clause A.4.

Note 3: Optical rise and fall time specifications are based on the unfiltered waveforms. For the purpose of standardizing the measurement method, measured waveforms shall conform to the mask as defined in FC-PI-2 figure 23. If filter is needed to conform to the mask the filter response effect should be removed from the measured rise and fall times using the equation:

$$\text{TRISE/FALL} = [(\text{TRISE/FALL_MEASURED})^2 - (\text{TRISE/FALL_FILTER})^2]^{1/2}$$

The optical signal may have different rise and fall times. Any filter should have an impulse response equivalent to a fourth order Bessel-Thomson Filter. See annex A.1.2.2

Note 4: See annex A.5.

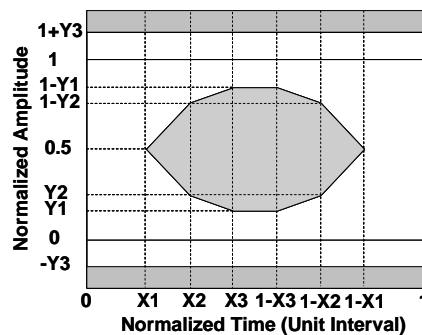

Figure.7.1. Transmission eye mask definition

Optical Receiver : 2/4/8GFC for OM1, OM2 and OM3

Parameter	Symbol	Min	Typ	Max	Unit
Wavelength		840		860	nm
Signaling Speed, 8GFC			8.5		Gb/s
Signaling Speed, 4GFC			4.25		Gb/s
Signaling Speed, 2GFC		-	2.125		Gb/s
Signaling speed variation from nominal (max)		-100		+100	ppm
Average receiver power				0	dBm
Receiver sensitivity in OMA, 8GFC				0.076	mW
Receiver sensitivity in OMA, 4GFC				0.061	mW
Receiver sensitivity in OMA, 2GFC				0.049	mW
Return loss of receiver		12			dB
Rx jitter tolerance test in OMA, 8GFC		0.2			mW
Rx jitter tolerance test in OMA, 4GFC		0.164(OM1) 0.154			mW
Rx jitter tolerance test in OMA, 2GFC		0.121(OM1) 0.107			mW
Stressed receiver sensitivity in OMA, 8GFC				0.155(OM1) 0.151(OM2) 0.148(OM3)	mW
Stressed receiver sensitivity in OMA, 4GFC				0.148(OM1) 0.138(OM2) 0.126(OM3)	mW
Stressed receiver sensitivity in OMA, 2GFC				0.109(OM1) 0.096(OM2) 0.083(OM3)	mW

Note 1 : Receiver sensitivity is informative. Stressed receiver sensitivity shall be measured with conformance test signal for BER=10⁻¹².

8. Electrical and Optical I/O Signal Relationship

Table.8.1. TX_DIS vs. Optical Output Power

TX_DIS	Optical Output Power
Low ($V_{IL} = -0.3$ to $0.8V$)	Enabled
High ($V_{IH} = 2.0$ to $VCC3 + 0.3V$)	Disabled ($< -30dBm$)

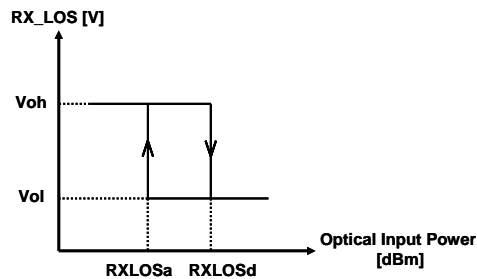

Figure.8.1. Optical Input Power vs. RX_LOS

9. User Interface

9.1. SFP Mechanical Interface

SFP Mechanical Interface is specified in the SFF-8432. Also, bail latch system is adequate for the particular specification.

9.2. Management Interface

SFP 2-Wire Serial Interface Protocol

SFP 2-wire serial interface is specified in the SFF-8472.

The SFP 2-wire serial interface is used for serial ID, digital diagnostics, and certain control functions. The 2-wire serial interface is mandatory for all SFP modules.

The 2-wire serial interface address of the SFP module is A0h and A2h. In order to access to a specific module on the 2-wire serial bus, the SFP has a MOD_ABS (module absent pin). This pin, which is pulled down in the module, must be held low to notify a module installation and to allow communication over 2-wire serial interface.

SFP Management Interface

SFP Managed interface is specified in the SFF-8472.

The Figure 9.2. shows the structure of the memory map. The normal 256 Byte address space is divided into lower and upper blocks of 128 Bytes. The lower block of 128 Byte is always directly available and is used for the diagnostics and control functions that must

be accessed repeatedly. Multiple blocks of memories are available in the upper 128 Bytes of the address space. These are individually addressed through a table select Byte which the user enters into a location in the lower address space. The upper address space tables are used for less frequently accessed functions and control space for future standards definition.

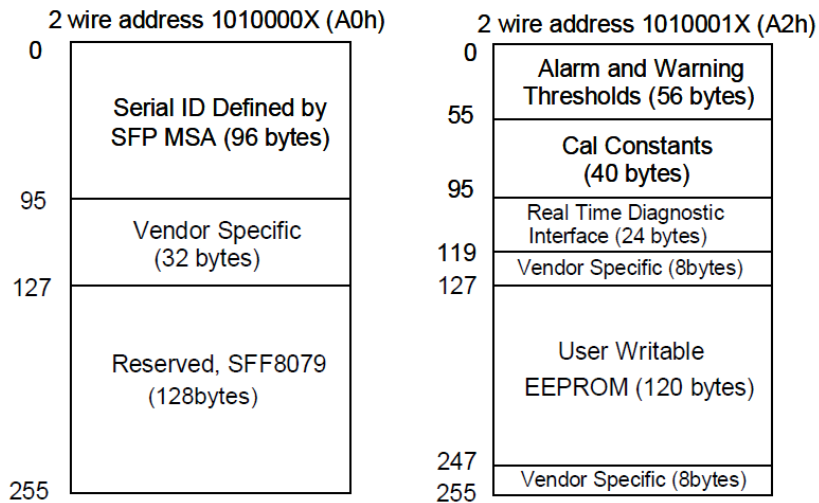

Figure 9.2. 2-wire Serial Interface Memory Map

9.3. Serial ID Memory Map (Data Field – Page 01h)

Address	Size (Bytes)	Name	Hex	ASC	Description	Address	Size (Bytes)	Name	Hex	ASC	Description	
0	1	Identifier	03		SFP module	64	2	Options	00		8GFC - SW, Limiting, Class1, Uncooled, TxDisable, TxFault, LOS, Rate_Select implemented	
1	1	Ext.Identifier	04		Serial ID module	65			3A			
2	1	Connector	07		LC Connector	66	1	BR,max	00			
3	8	Transceiver	00			67	1	BR,min	00			
4			00			68	16	Vendor SN	20			
5			00			69			20			
6			00			70			20			
7			40			71			20			
8			40	8GFC-SW		72			20			
9			0C	8GFC-SW		73			20			
10			54	8GFC-SW		74			20			
11	1	Encoding	01		8B10B	75			20			
12	1	BR, Nominal	55		8.5Gbps	76			20			
13	1	Rate Identifier	03		Rate_Select	77			20			
14	1	Length(9um, km)	00		not support SMF	78			20			
15	1	Length(9um)	00		not support SMF	79			20			
16	1	Length(50um)	05		50m for OM2	80			20			
17	1	Length(62.5um)	03		21m for OM1	81			20			
18	1	Length(Copper)	00		not support copper	82			20			
19	1	Length(OM3)	0F		150m for OM3	83			20			
20	16	Vendor name	53	S		84	8	Date Code	xx		Year code	
21			75	u		85			xx			
22			6D	m		86			xx		Month code	
23			69	i		87			xx			
24			74	t		88			xx		Day code	
25			6F	o		89			xx			
26			6D	m		90			xx		LOT code	
27			6F	o		91			xx			
28			45	E		92	1	Diagnostis Monitoring Type	68		Internal cal., Average Power Alarm/Warning flags, Soft TxDisable, Soft TxFault, Soft RxLOS, Soft RS	
29			6C	l		93	1	Enhanced Options	FA		Rev 10.0	
30			65	e		94	1	SFF-8472 Compliance	03		Check Code *3	
31			63	c		95	1	CC_EXT	xx			
32			74	t		96-126	32	Vendor Specific	xx			
33			72	r		127-255	125	Reserved	00			
34			69	i								
35			63	c								
36	1	Channel Spacing	00									
37	3	Vendor OUI	00									
38			00									
39			5F									
40	16	Vendor PN	53	S								
41			50	P								
42			50	P								
43			35	5								
44			31	1								
45			30	0								
46			31	1								
47			53	S								
48			58	X								
49			2D	-								
50			47	G								
51			4C	L								
52			20									
53			20									
54			20									
55			20									
56	4	Vendor rev	4E	A	*1							
57	4	Vendor rev	20									
58			20									
59			20									
60	2	Wavelength	03									
61			52									
62	1	DWDM Wavelength	00									
63	1	CC_BASE	E0		Check Code *2							

*1 : Revision level for part number provided by vendor (ASCII). Variable
 *2 : Checksum of Add.0 to 62
 *3 : Checksum of Add.64 to 94

Note 1.The guaranteed +/- range of transmitter output wavelength under all normal operating conditions.

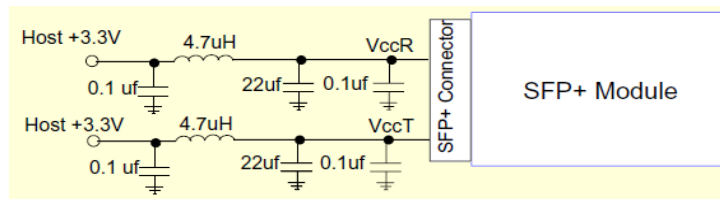

Figure 9.5. Supply Filter

9.4. Alarm/Warning threshold

A2h address	Meaning	Unit	SPP5101SR-GL
0-1	Temperature High Alarm	deg	75
2-3	Temperature Low Alarm	deg	-5
4-5	Temperature High Warning	deg	70
6-7	Temperature Low Warning	deg	0
8-9	Voltage High Alarm	V	3.63
10-11	Voltage Low Alarm	V	2.97
12-13	Voltage High Warning	V	3.465
14-15	Voltage Low Warning	V	3.135
16-17	Tx Bias High Alarm	mA	10.5
18-19	Tx Bias Low Alarm	mA	2
20-21	Tx Bias High Warning	mA	9
22-23	Tx Bias Low Warning	mA	2.5
24-25	Tx Power High Alarm	dBm	1.7
26-27	Tx Power Low Alarm	dBm	-14
28-29	Tx Power High Warning	dBm	-1.3
30-31	Tx Power Low Warning	dBm	-10
32-33	Rx Power High Alarm	dBm	3
34-35	Rx Power Low Alarm	dBm	-17.3
36-37	Rx Power High Warning	dBm	0
38-39	Rx Power Low Warning	dBm	-13.3

Note.

- Alarm /Warning flag is linked to TxFault by default setting.

10. RoHS COMPLIANCY

Compliance versus requirements contained inside the following reference document is guaranteed: Directive 2002/95/EC of 27 January 2003 on the restriction of the use of certain hazardous substances in electrical and electronic equipment from official journal of European Union (European Parliament and of the Council). This product is Compliant at RoHS-6/6 level and contains no leaded solders.

11. Qualification Testing

SPP5100SX-GL 8Gb/s transceiver is qualified to Sumitomo Electric Industries internal design and manufacturing standards. Telecordia GR-468-CORE reliability test standards, using methods per MIL-STD-883 for mechanical integrity, endurance, moisture, flammability and ESD thresholds, are followed.

12. Laser Safety Information

SPP5100SX-GL transceiver uses a semiconductor laser system that is classified as Class 1 laser products per the Laser Safety requirements of FDA/CDRH, 21 CFR1040.10 and 1040.11. These products have also been tested and certified as Class 1 laser products per IEC 60825-1:2001 International standards.

Caution

If this product is used under conditions not recommended in the specification or is used with unauthorized revision, the classification for laser product safety is invalid. Reclassify the product at your responsibility and take appropriate safety measures.

13. Electromagnetic Compatibility

EMI (Emission)

SPP5100SX-GL is designed to meet FCC Class B limits for emissions and noise immunity per CENELEC EN50 081 and 082 specifications.

RF Immunity

SPP5100SX-GL has an immunity to operate when tested in accordance with IEC 61000-4-3 (80- 1000MHz, Test Level 3) and GR-1089.

Electrostatic Discharge (ESD) Immunity

SPP5100SX-GL has an immunity against direct and indirect ESD when tested accordance with IEC 61000-4-2.

14. Ordering Information

14.1. Part Numbering System

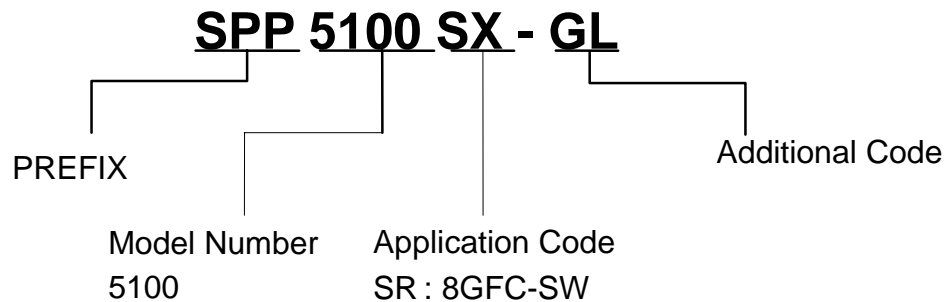

14.2. Ordering Number Code

Table 13-1. SPP5100SX Application Code

P/N	Distance	Fiber	E/O	O/E	ITU-T G.691	Telecordia GR-253	FC-PI-4
SPP5100SX-GL	150m	MMF	850nm VCSEL	PIN	-	-	8GFC-SW

14.3. Firmware version

This product contains the firmware inside. Sumitomo Electric may upgrade the firmware version without advance notice as far as such would be upper compatible. When customer should prefer to have the current firmware version, Sumitomo Electric will accommodate such request and will assign customized part number for this purpose.

14.4. 2-wire Serial Interface

If the serial clock(SCL) is more than 100kHz, the SCL is held in line low (clock stretching) during an 2-WIRE SERIAL INTERFACE read or white operation.

15. Label information



16. Contact Information

U.S.A.

ExceLight Communications, 4021 Stirrup Creek Drive, Suite 200 Durham, NC 27703

Tel. +1-919-361-1600 / Fax. +1-919-361-1619

E-mail: info@excelight.com

<http://www.excelight.com>

Europe

Sumitomo Electric Europe Ltd., 220, Centennial Park, Elstree, Herts, WD6 3SL, United Kingdom

Tel. +44-208-953-8681

Fax. +44-208-207-5950

E-mail: photonics@sumielectric.com

<http://www.sumielectric.com>

Japan

Sumitomo Electric Industries, Ltd.

1, Taya-cho, Sakae-ku, Yokohama, 244-8588

Tel. +81-45-853-7154 / Fax. +81-45-851-1932

E-mail: product-info@ppd.sei.co.jp

<http://www.sei.co.jp/Electro-optic/index.html>