

10Gb/s SFP Optical Transceiver Module

SPP5200SR-GL-M

(10GBASE-SR & Multi-Protocol, 850nm VCSEL, PIN-PD)

Features

- ◆ 10Gb/s Serial Optical Interface
 - High quality/reliability optical device and sub-assemblies
 - 850nm VCSEL laser for up to MMF 300m and high sensitivity PIN photodiode with TIA
 - 10GBase-SR & multi-protocol compliance
- ◆ SFP+ MSA Compliant
 - Compliant with SFF 8431 for electrical interface
 - SFI High Speed electrical interface
 - Tx_Disable and Rx_LOS function supported
 - Compliant with SFF 8432 for mechanical interface
 - SFP Mechanical Interface for easy removal
 - Duplex LC Receptacle
 - Compliant with SFF 8742 for 2-wire interface for management and diagnostic monitor
- ◆ Protocol
 - IEEE802.3ae 10 Gigabit Ethernet with LAN PHY/WAN PHY and FEC rate
 - FC-PI-4 10G Fiber Channel and FEC rate
- ◆ Power Supply Consumption
 - Less than 1W with single 3.3V power supply
 - -5 to 85 degree Celsius operation (SPP5200SR-GL-M)
- ◆ RoHS6 compliant



Applications

- ◆ 10GE Ethernet switches and routers
- ◆ 10GE Storage
- ◆ 10GFC system
- ◆ Inter Rack Connection
- ◆ Other high speed data connections

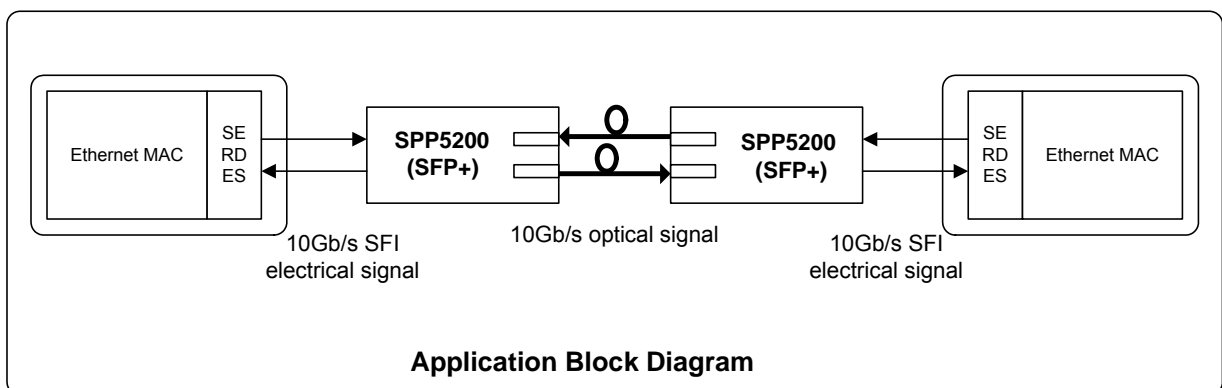

Preliminary

1. General Description

The SPP5200SR-GL-M is a very compact 9.9 to 11.3Gb/s optical transceiver module for serial optical communication applications at 10GBase-SR or other multi-protocol. Also its operation case temperature range is specified under -5 to 85 degree Celsius for SPP5200SR-GL, which converts a 10Gb/s serial electrical data stream to 10Gb/s optical output signal and a 10Gb/s optical input signal to 10Gb/s serial electrical data streams. The high speed 10Gb/s electrical interface is fully compliant with SFI specification of SFF-8431. The SPP5200SR-GL-M is designed for Ethernet LAN/WAN, 10GFC and FEC rate applications. The high performance 850nm VCSEL transmitter and high sensitivity PIN receiver provide superior performance for such multi-protocol at up to 300m links. The fully SFP+ MSA compliant form factor provides hot pluggability, easy optical port upgrades and low EMI emission.

Table 1. Fiber compliance

SFP+ type	Wavelength [nm]	Cable Type	Core Size (micron)	Modal Bandwidth [MHz/km]	Cable distance
10GB-SR	850	MMF	62.5	160	26m(FDDI-Grade)
			62.5	200	33m(OM1)
			50.0	400	66m
			50.0	500	82m(OM2)
			50.0	2000	300m(OM3)
10GFC	850	MMF	62.5	200	33m
			50.0	500	82m
			50.0	2000	300m

2. Functional Description

The SPP5200SR-GL-M contains a duplex LC connector for the optical interface and a 20-pin connector for the electrical interface. Figure 2.1 shows the functional block diagram of SPP5200SR-GL-M SFP Transceiver.

Transmitter Operation

The transceiver module receives 10Gb/s electrical data and transmits the data as an optical signal. The transmitter output can be turned off by Tx disable signal, TX_DIS pin. When TX_DIS is asserted High, Transmitter is turned off.

Preliminary

Receiver Operation

The received optical signal is converted to serial electrical data signal. The RX_LOS signal indicates insufficient optical power for reliable signal reception at the receiver.

Management Interface

A 2-wire interface (SCL, SDA) is used for serial ID, digital diagnostics and other control /monitor functions.

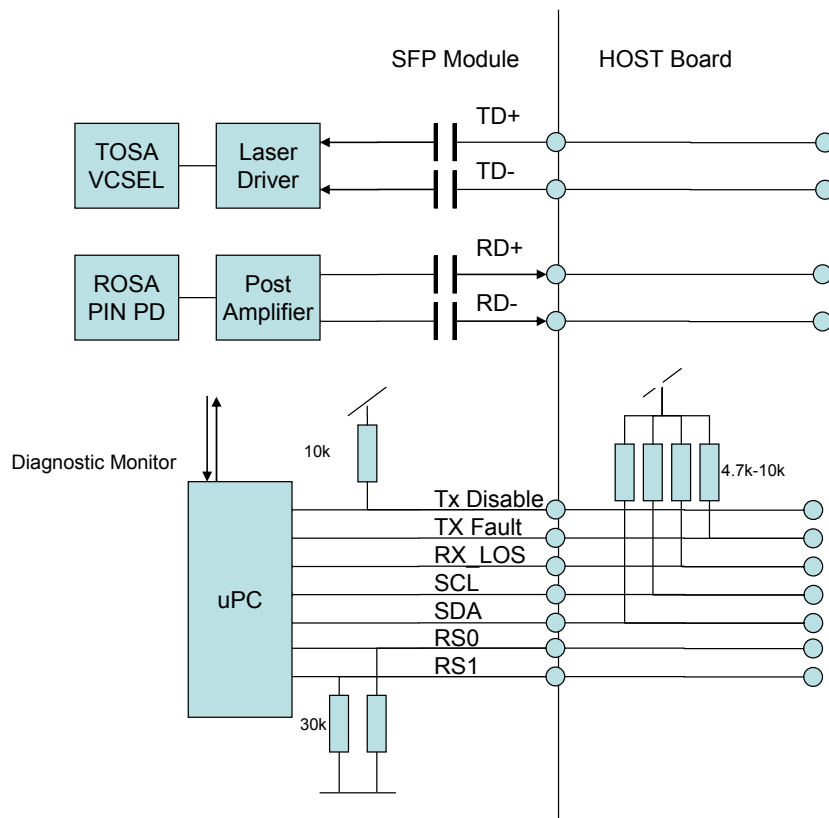

Figure 2.1 Functional Block Diagram

Preliminary

3. Package Dimensions

Figure 3.1 shows the package dimensions of SPP5200SR-GL-M, which is designed to be compliant with SFP MSA specification. Package dimensions are specified in SFF-8432.

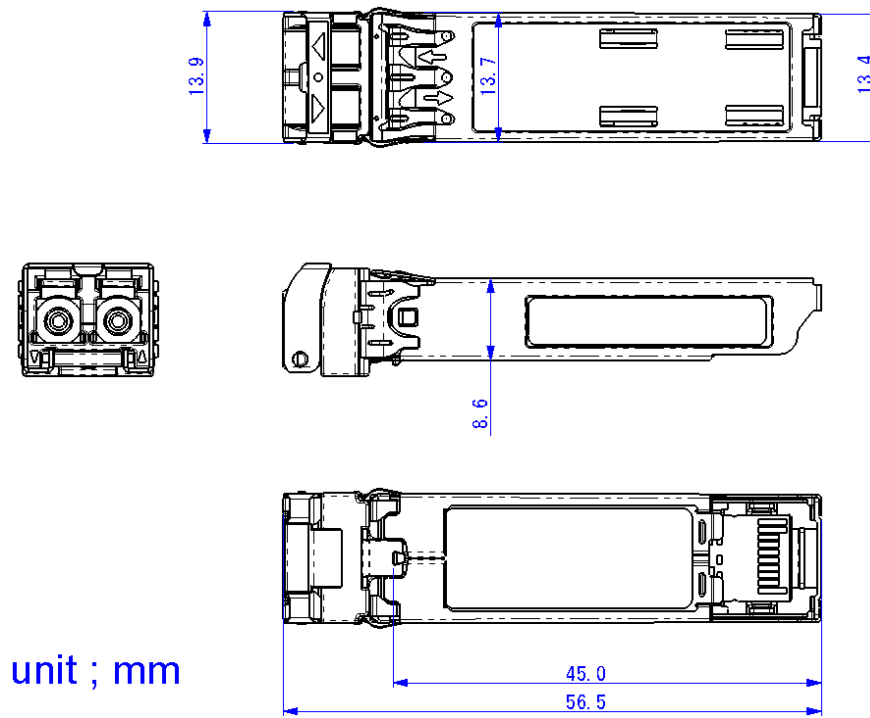

Figure 3.1 Package dimensions

Preliminary

4. Pin Assignment and Pin Description

4.1. SFP Transceiver Electrical Pad Layout

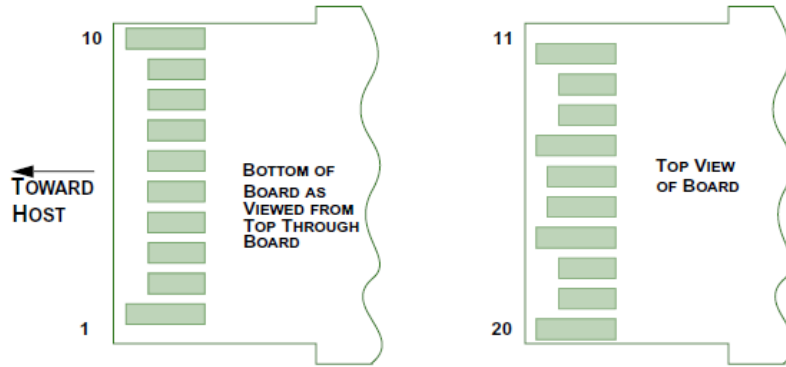

Figure 4.1 SFP Transceiver Electrical Pad Layout

4.2. Host PCB SFP Pinout

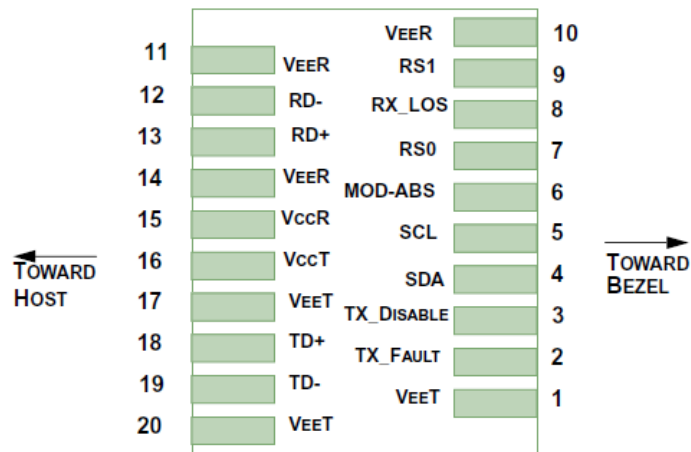

Figure 4.2 Host PCB SFP Pinout

4.3. Pin Descriptions

Table 4.3. Pin Description

Pin#	Name	Logic	Description	Power Sequence Order	Note
1	VeeT		Module Transmitter Ground	1 st	1
2	Tx_Fault	LVTTL-O	Module Transmitter Fault	3 rd	2
3	Tx_Disable	LVTTL-I	Transmitter Disable, Turns off transmitter laser output	3 rd	3
4	SDA	LVTTL-I/O	2 Wire Serial Interface Data Line(Same as MOD-DEF2 as defined in the INF-8074i)	3 rd	
5	SCL	LVTTL-I/O	2 Wire Serial Interface Data Line(Same as MOD-DEF1 as defined in the INF-8074i)	3 rd	
6	MOD_ABS		Module Absent, connected to VeeT or VeeR in the module	3 rd	2
7	RS0	LVTTL-I	Rate Select 0 (not functional for 10GE type)	3 rd	
8	RX_LOS	LVTTL-O	Receiver Loss of Signal Indication	3 rd	2
9	RS1	LVTTL-I	Rate Select 1 (not functional for 10GE type)	3 rd	
10	VeeR		Module Receiver Ground	1 st	1
11	VeeR		Module Receiver Ground	1 st	1
12	RD-	CML-O	Receiver Inverted Data Output	3 rd	
13	RD+	CML-O	Receiver Non-Inverted Data Output	3 rd	
14	VeeR		Module Receiver Ground	1 st	1
15	VccR		Module Receiver 3.3V Supply	2 nd	
16	VccT		Module Transmitter 3.3V Supply	2 nd	
17	VeeT		Module Transmitter Ground	1 st	1
18	TD+	CML-I	Transmitter Non-Inverted Data Input	3 rd	
19	TD-	CML-I	Transmitter Inverted Data Input	3 rd	
20	VeeT		Module Transmitter Ground	1 st	1

Note

- 1: Module ground pins are isolated from the module case and chassis ground within the module.
- 2: Shall be pulled up with 4.7k to 10k ohm to a voltage between 3.15V and 3.45V on the host board.
- 3: Shall be pulled up with 4.7k to 10k ohm to VccT in the module.

Preliminary

5. Absolute Maximum Ratings and Recommended Operating Conditions

Table 5.1. Absolute Maximum Ratings

Parameter	Symbol	Min	Max	Unit	Note
Storage Temperature	Tst	-40	85	degC	
Relative Humidity (non-condensation)	RH	-	85	%	
Operating Case Temperature	Topc	-5	85	degC	1
Supply Voltage	VccR/VccT	-0.5	3.6	V	
Voltage on LVTTTL Input	Vilvttl	-0.5	VCC3+0.5	V	
LVTTTL Output Current	Iolvttl	-	15	mA	
Voltage on Open Collector Output	Voco	0	6	V	
Receiver Input Optical Power(Average)	Mip	-	0	dBm	

Note:

1: Typical Ta: -10 to 60degC with 1.5m/s airflow

Table 5.2. Recommended Operating Conditions and Supply Requirements

Parameter	Symbol	Min	Max	Unit	Note
Operating Case Temperature	Topc	-5	85	degC	
Relative Humidity(non-condensing)	Rhop	-	85	%	
Power Supply Voltage	VccR/VccT	3.135	3.465	V	
Total Power Consumption	Pd	-	1.0	W	1

Note:

1: The inrush current meets SFF-8431 level-I operation.

Preliminary

6. Electrical Interface

6.1. High Speed Electrical Interface

SFI Application Reference model

Figure 6.1.1. shows the high speed electrical interface (SFI) compliance points.

SFI electrical interface is specified for each compliance point in the SFP MSA specification.

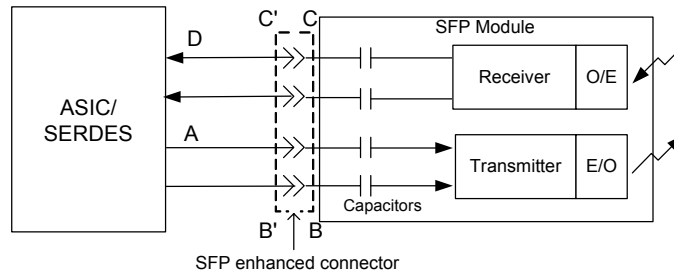

Figure 6.1.1. SFI Application Reference Model

SFI Module Transmitter Input Electrical Interface Specification at B' and Calibrated B''

Table 6.1.1. SFI Transmitter Input Electrical Specification at B'

Parameter B'	Symbol	Condition	Min	Typ.	Max.	Unit
Single Ended Output Voltage Tolerance		Referenced to VeeT	-0.3		4.0	V
AC common Input S-parameter		Note 1	15			mV
Differential Input S-parameter (note 1)	SDD11	0.01-4.1GHz			Note 2	dB
		4.1-11.1GHz			Note 3	dB
Reflected Differential to Common Mode Conversion	SCD11	0.01-11.1GHz			-10	dB

Note 1. Measured at B'' with Host Compliance Board and Module Compliance Board pair.

2. Maximum Reflection Coefficient given by equation $SDD11(dB) = -12 + 2 * \sqrt{f}$, with f in GHz.

3. Maximum Reflection Coefficient given by equation $SDD11(dB) = -6.3 + 13 \log_{10}(f/5.5)$, with f in GHz

Table 6.1.2. SFI Transmitter Input Electrical Specification at B"

Parameter B"	Symbol	Condition	Min	Typ.	Max.	Unit
Crosstalk Source Rise/Fall time (20% to 80%)	Tr, Tf	Note 1, 2		34		ps
Crosstalk Source Amplitude (p-p differential)		Note 1, 2		1000		mV
AC Common Mode Voltage		Note 3			15	mV(RMS)
Total Jitter	TJ				0.28	UIpp
Data Dependent Jitter	DDJ			0.10		UIpp
Pulse Width Shrinkage Jitter	DDPWS			0.055		UIpp
Uncorrelated Jitter	UJ	Note 4		0.023		UIrms
Eye Mask Figure 6.1.2	X1			0.12		UI
	X2			0.33		UI
	Y1			95		mV
	Y2			350		mV

- Note
1. Measured at C" with Host Compliance Board and Module Compliance Board pair.
 2. Since the minimum module output transition time is faster than the crosstalk transition time the amplitude of crosstalk source is increased to achieve the same slew rate.
 3. The tester is not expected to generate this common mode voltage however its output must not exceed this value.
 4. It is not possible to have the worst UJ and DDJ simultaneously and meet the TJ specifications if the UJ is all Gaussian.

SFI Module Receiver Output Electrical Interface Specification at C'

Table 6.1.3. SFI Receiver Output Electrical Specification at C'

Parameter – C'	Symbol	Conditions	Min	Typ	Max	Units
Crosstalk source rise/fall time (20% to 80%)	Tr, Tf	Note 1		34		ps
Crosstalk Source Amplitude Differential (p-p)		Note 2		700		mV
Termination Mismatch at 1 MHz	ΔZ_M				5	%
Single Ended Output Voltage Tolerance			-0.3		4.0	V
Output AC Common Mode Voltage					7.5	mV (RMS)
Differential Output S-parameter (Note 3)	SDD22	0.01-4.1GHz			Note 2	dB
		4.1-11.1GHz			Note 3	dB
Common Mode Output Reflection Coefficient (Note 5)	SCC22	0.01-2.5GHz			Note 4	dB
		2.5-11.1GHz			-3	dB

Note 1 : Measured at B" with the Host Compliance Board and Module Compliance Board pair.

2 : Reflection Coefficient given by equation $SDD22(dB) < -12 + 2 \times \text{SQRT}(f)$, with f in GHz.

3 : Reflection Coefficient given by equation $SDD22(dB) < -6.3 + 13 \times \log_{10}(f/5.5)$, with f in GHz.

4 : Reflection coefficient given by equation $SCC22(dB) < -7 + 1.6 \times f$, with f in GHz.

Preliminary

Table 6.1.4. SFP+ Limiting Output Jitter and Eye Mask Specification at C'

Parameter – C'	Symbol	Conditions	Min	Typ	Max	Units
Output rise/fall time (20% to 80%)	Tr, Tf		28			ps
Total Jitter	TJ				0.70	U _{Ipp}
99% Jitter	J2	Note 1			0.42	U _{Ipp}
Eye Mask Figure 6.1.3	X1		0.35			UI
	Y1		150			mV
	Y2		425			mV

Note 1 : J2 is defined from the 0.5th to the 99.5th percentile of the jitter histogram.

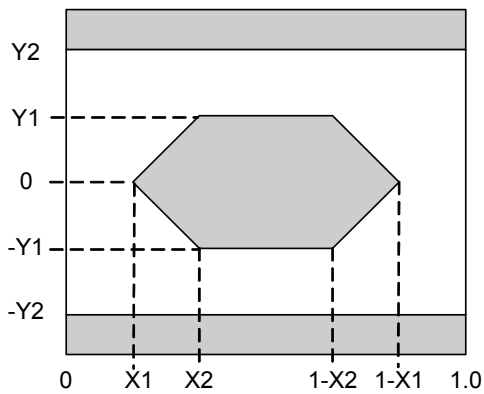

Figure 6.1.2.
Transmitter Input Eye Mask

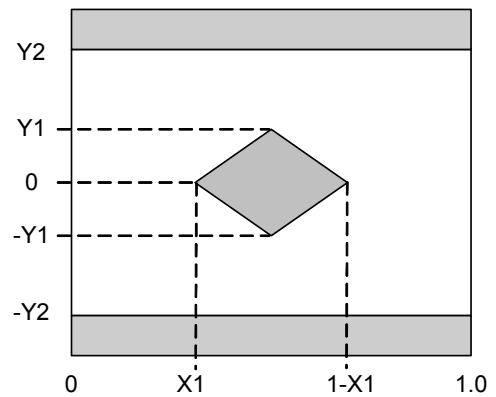

Figure 6.1.3.
Receiver Output Eye Mask

Preliminary

6.2. Low speed Electrical Interface

SPP5200SR-GL-M low speed interface is based on 2-wire interface. Management memory map is based on SFF-8472.

2-wire Electrical Specifications

Parameter	Symbol	Min	Max	Unit
Host 2-wire Vcc	Vcc_host	3.14	3.46	V
SCL and SDA	V _{OL}	0.0	0.40	V
	V _{OH}	Vcc_host-0.5	Vcc_host+0.3	V
SCL and SDA	V _{IL}	-0.3	VccT*0.3	V
	V _{IH}	VccT*0.7	VccT+0.5	V
Input current on the SCL and SDA contacts		-10	10	uA
Capacitance on SCL and SDA I/O contact			14	pF

2-wire Timing Specifications

Parameter	Symbol	Min	Max	Unit
Clock Frequency	f _{SCL}	0	400	KHz
Clock Pulse Width Low	t _{LOW}	1.3		us
Clock Pulse Width High	t _{HIGH}	0.6		us
Time bus free before new transmission can start	t _{BUF}	20		us
START Hold Time	t _{HD, STA}	0.6		us
START Set-up Time	t _{SU, STA}	0.6		us
Data In Hold Time	t _{HD, DAT}	0		us
Data In Set-up Time	t _{SU, DAT}	0.1		us
Input Rise Time (100kHz)	t _{R, 100}		1000	ns
Input Rise Time (400kHz)	t _{R, 400}		300	ns
Input Fall Time (100kHz)	t _{F, 100}		300	ns
Input Fall Time (400kHz)	t _{F, 400}		300	ns
STOP Set-up Time	t _{SU, STO}	0.6		us
Serial Interface Clock Holdoff "Clock Stretching" (Note 1)	t _{clock_hold}		500	us

Note 1 : If the serial clock (SCL) is more than 100kHz, the SCL is held in line low (clock stretching) during an 2-WIRE SERIAL INTERFACE read or white operation.

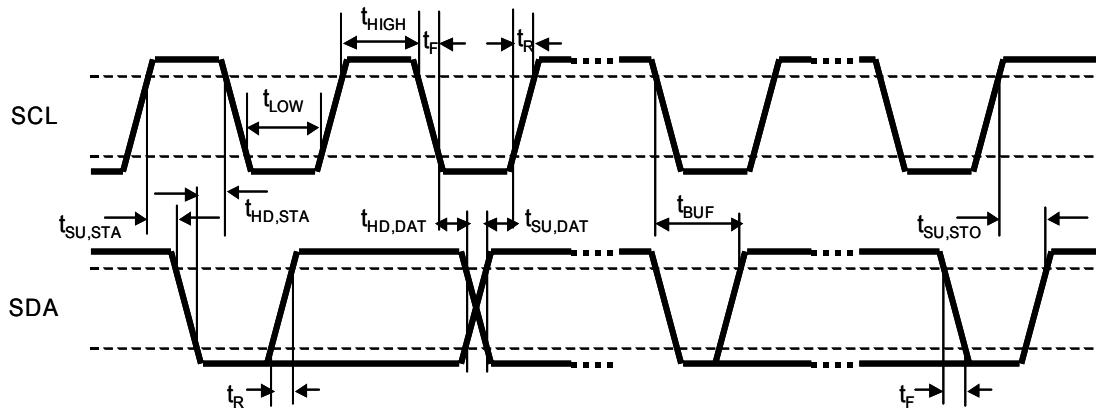

Figure 6.1.4. SFP+ Timing Diagram

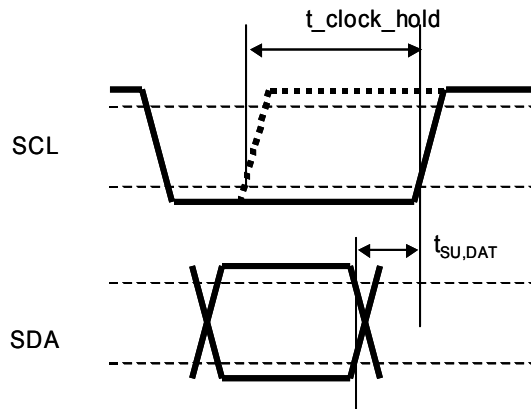

Figure 6.1.5. Detail of Clock Stretching

7. Optical Interface

Optical Interfaces of SPP5200SR-GL-M are defined in the IEEE802.3ae(10GBASE-SR) and FC-FI-4(10GFC).

Optical Transmitter

Parameter	Symbol	Min	Typ	Max	Unit
Signaling Speed (LAN PHY) (WAN PHY) (10GFC)		-	10.3125 9.95328 10.51875		Gb/s
Signaling speed variation from nominal (max)		-100		+100	ppm
Center wavelength		840		860	nm
RMS spectral width	λ_{rms}	Refer to Table 7.1			nm
Average launched power	P_{ave}	-7.3		-1.3	dBm
OMA	P_{oma}	Refer to Table 7.1 and Figure 7.2			dBm
Transmitter and dispersion penalty				3.9	dB
Average launch power of Tx OFF				-30	dBm
Extinction ratio		3.0			dB
RIN OMA				-128	dB/Hz
Optical Return Loss Tolerance				12	dB
Eye mask(X1,X2,X3,Y1,Y2,Y3)	(0.25,0.40,0.45,0.25,0.28,0.40) Note 1				

Trade-offs are available between spectral width, center wavelength and minimum optical modulation amplitude. Refer Table.7.1 and Figure 7.2.

Note 1: Refer to Figure 7.1.

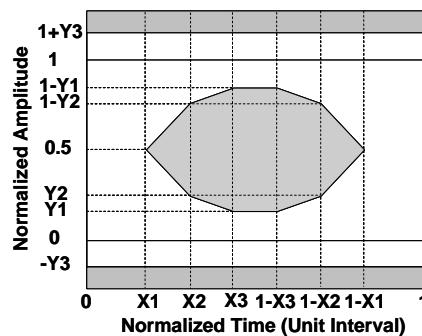

Figure.7.1. Transmission eye mask definition

Preliminary

Table7.1: Minimum OMA as a function of Center Wavelength and Spectral Width

Center Wavelength(nm)	RMS Spectral width (nm)								
	Up to 0.05	0.05 to 0.1	0.1 to 0.15	0.15 to 0.2	0.2 to 0.25	0.25 to 0.3	0.3 to 0.35	0.35 to 0.4	0.4 to 0.45
840 to 842	-4.2	-4.2	-4.1	-4.1	-3.9	-3.8	-3.5	-3.2	-2.8
842 to 844	-4.2	-4.2	-4.2	-4.1	-3.9	-3.8	-3.6	-3.3	-2.9
844 to 846	-4.2	-4.2	-4.2	-4.1	-4.0	-3.8	-3.6	-3.3	-2.9
846 to 848	-4.3	-4.2	-4.2	-4.1	-4.0	-3.8	-3.6	-3.3	-2.9
848 to 850	-4.3	-4.2	-4.2	-4.1	-4.0	-3.8	-3.6	-3.3	-3.0
850 to 852	-4.3	-4.2	-4.2	-4.1	-4.0	-3.8	-3.6	-3.4	-3.0
852 to 854	-4.3	-4.2	-4.2	-4.1	-4.0	-3.9	-3.7	-3.4	-3.1
854 to 856	-4.3	-4.3	-4.2	-4.1	-4.0	-3.9	-3.7	-3.4	-3.1
856 to 858	-4.3	-4.3	-4.2	-4.1	-4.0	-3.9	-3.7	-3.5	-3.1
858 to 860	-4.3	-4.3	-4.2	-4.2	-4.1	-3.9	-3.7	-3.5	-3.2

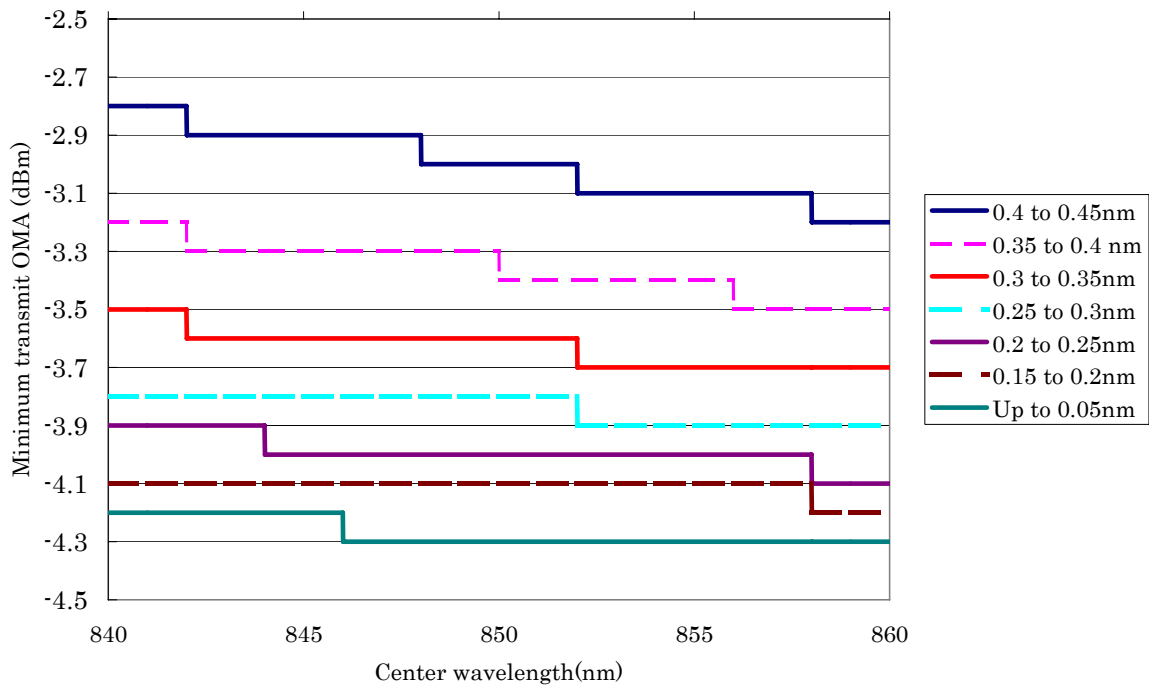

Figure 7.2:Trade-offs OMA-Center wavelength

Preliminary

Optical Receiver

Parameter	Symbol	Min	Typ	Max	Unit
Wavelength		840		860	nm
Signaling Speed (LAN PHY) (WAN PHY) (10GFC)			10.3125 9.95328 10.51875		Gb/s
Signaling speed variation from nominal (max)		-100		+100	ppm
Average receiver power		-9.9		-1.0	dBm
Receiver sensitivity in OMA				-11.1	dBm
Receiver Reflectance				-12	dB
Stressed receiver sensitivity in OMA				-7.5	dBm
Vertical eye closure penalty		3.5			dB
Stressed ey jitter		0.3			Upp
Receive electrical 3dB upper cutoff frequency				12.3	GHz

Note 1 : Receiver sensitivity is informative. Stressed receiver sensitivity shall be measured with conformance test signal for BER=10⁻¹².

LOS Assert/De-assert Level

	Rx Average Power Sensitivity (unstressed) [dBm]	Rx_LOS Assert Min [dBm] Note 1	Rx_LOS Assert Max [dBm] Note 2	Rx_LOS De^Assert Max [dBm] Note 3
10GE-SR	-9.9	-30	-16	-13
10FFC-SW	-9.9			

Note 1 : The Rx_LOS alarm is asserted when the optical input power level is below the specified value.

2 : The Rx_LOS alarm is not asserted until the optical input power level is below the specified value.

3 : The Rx_LOS alarm is de-asserted when the optical power level ia above the specified value.

8. Electrical and Optical I/O Signal Relationship

Table.8.1. TX_DIS vs. Optical Output Power

TX_DIS	Optical Output Power
Low ($V_{IL} = -0.3$ to $0.8V$)	Enabled
High ($V_{IH} = 2.0$ to $VCC3+0.3V$)	Disabled ($<-30dBm$)

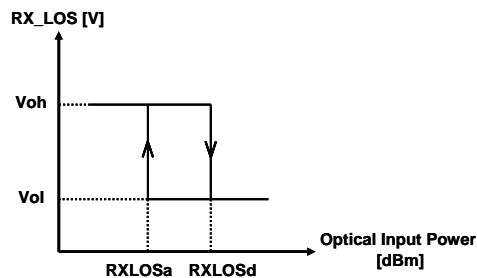

Figure.8.1. Optical Input Power vs. RX_LOS

9. User Interface

9.1. SFP Mechanical Interface

SFP Mechanical Interface is specified in the SFF-8432. Also, bail latch system is adequate for the particular specification.

9.2. Management Interface

SFP 2-Wire Serial Interface Protocol

SFP 2-wire serial interface is specified in the SFF-8472.

The SFP 2-wire serial interface is used for serial ID, digital diagnostics, and certain control functions. The 2-wire serial interface is mandatory for all SFP modules.

The 2-wire serial interface address of the SFP module is A0h and A2h. In order to access to a specific module on the 2-wire serial bus, the SFP has a MOD_ABS (module absent pin). This pin, which is pulled down in the module, must be held low to notify a module installation and to allow communication over 2-wire serial interface.

SFP Management Interface

SFP Managed interface is specified in the SFF-8472.

The Figure 9.2. shows the structure of the memory map. The normal 256 Byte address space is divided into lower and upper blocks of 128 Bytes. The lower block of 128 Byte is always directly available and is used for the diagnostics and control functions that must be

Preliminary

accessed repeatedly. Multiple blocks of memories are available in the upper 128 Bytes of the address space. These are individually addressed through a table select Byte which the user enters into a location in the lower address space. The upper address space tables are used for less frequently accessed functions and control space for future standards definition.

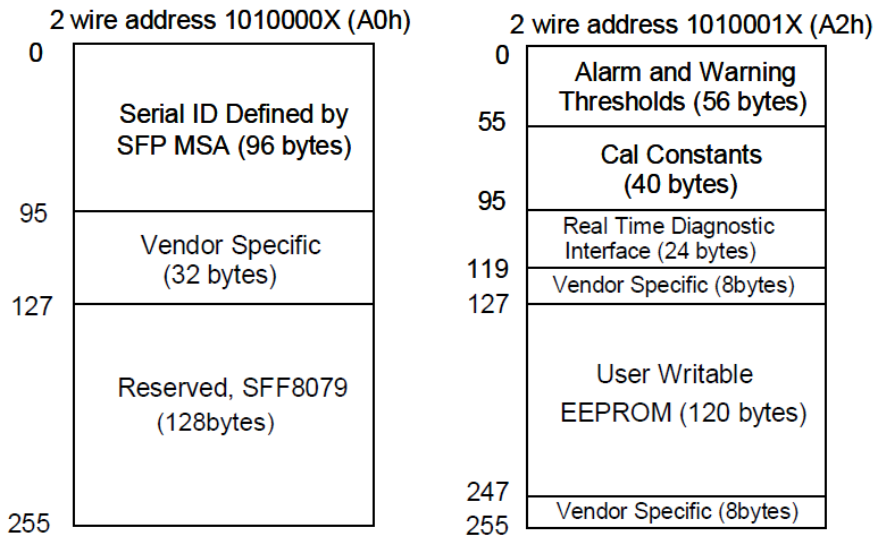

Figure 9.1. 2-wire Serial Interface Memory Map

To identify multi-sourcing OSA, vendor revision byte can be utilized as described memory map table.

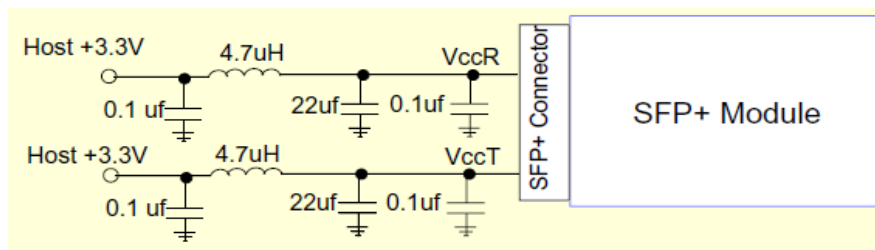

Figure 9.2 Supply Filter

Preliminary

9.3. Serial ID Memory Map (Data Field – Address A0h)

Address	Size (Bytes)	Name	Hex	ASC	Description	
0	1	Identifier	03		SFP module	
1	1	Ext.Identifier	04		Serial ID module	
2	1	Connector	07		LC Connector	
3	1		10		10GE BASE-SR	
4	1	Transceiver	00			
5	1		00			
6	1		00			
7	1		00			
8	1		00			
9	1		00			
10	1		00			
11	1	Encoding	06		64B66B	
12	1	BR-Min	67		10.3Gbps	
13	1	BR-Max	00		unspecified	
14	1	Length(SMF)-km	00		not support SMF	
15	1	Length(E-50 μm)	00		not support SMF	
16	1	Length(50 μm)	08		82m for OM2	
17	1	Length(62.5 μm)	02		26m for OM1	
18	1	Length(Copper)	00		not support copper	
19	1	Length(OM3)	1E		300m for OM3	
20	1	Vendor name	53	S		
21	1		75	u		
22	1		6D	m		
23	1		69	i		
24	1		74	t		
25	1		6F	o		
26	1		6D	m		
27	1		6F	o		
28	1		45	E		
29	1		6C	l		
30	1		65	e		
31	1		63	c		
32	1		74	t		
33	1		72	r		
34	1		69	i		
35	1		63	c		
36	1	Reserved	00			
37	1		00			
38	3	Vendor OUI	00			
39	3		5F			
40	1	Vendor PN	53	S		
41	1		50	P		
42	1		50	P		
43	1		35	5		
44	1		32	2		
45	1		30	0		
46	1		30	0		
47	1		53	S		
48	1		52	R		
49	1		2D	-		
50	1		47	G		
51	1		4C	L		
52	1		2D	-		
53	1		4D	M		
54	1		20			
55	1		20			
56	1	41	A		*1	
57	1	20				
58	1	20				
59	1	20				
60	2	Wavelength	03			
61	2		52			
62	1	Reserved	00			
63	1	CC BASE	xx		Check Code *2	

Address	Size (Bytes)	Name	Hex	ASC	Description	
64	2	Options	00		Power Class 1, limit Receiver Output	
65	2		1A		1xDisable, 1xFault, LOS implemented	
66	1	BR,max	00			
67	1	BR,min	00			
68	1	Vendor SN	xx			
69	1		xx			
70	1		xx			
71	1		xx			
72	1		xx			
73	1		xx			
74	1		xx			
75	1		xx			
76	1		xx			
77	1		xx			
78	1		xx			
79	1		xx			
80	1		xx			
81	1		xx			
82	1		xx			
83	1		xx			
84	1	Date Code	xx			
85	1		xx			
86	1		xx			
87	1		xx			
88	1		xx			
89	1		xx			
90	1		xx			
91	1		xx			
92	1	Diagnosis Monitoring Type	68		Internal cal, Average Power	
93	1	Enhanced Options	F0		Alarm/Warning flags, Soft TxDisable, Soft TxFault, Soft RxLOS implemented	
94	1	SFF-8472 Compliance	03		Rev.10.0	
95	1	CC EXT	xx		Check Code *3	
96-127	32	Vendor Specific	00			
128-255	128	Reserved	00			

*1 : Revision level for part number provided by vendor (ASCII). Variable.
And it identifies OSA source. (ex. Rev. A : prime source, Rev. A2 : second source)
*2 : Checksum of Add.0 to 62
*3 : Checksum of Add.64 to 94

Preliminary

9.4. Alarm/Warming threshold

A2h address	Meaning	Unit	SPP5200SR-M
0-1	Temperature High Alarm	deg	90
2-3	Temperature Low Alarm	deg	-10
4-5	Temperature High Warning	deg	85
6-7	Temperature Low Warning	deg	-5
8-9	Voltage High Alarm	V	3.63
10-11	Voltage Low Alarm	V	2.97
12-13	Voltage High Warning	V	3.465
14-15	Voltage Low Warning	V	3.135
16-17	Tx Bias High Alarm	mA	15 (TBD)
18-19	Tx Bias Low Alarm	mA	2 (TBD)
20-21	Tx Bias High Warning	mA	14 (TBD)
22-23	Tx Bias Low Warning	mA	2.4(TBD)
24-25	Tx Power High Alarm	dBm	1.5
26-27	Tx Power Low Alarm	dBm	-11.3
28-29	Tx Power High Warning	dBm	-1.5
30-31	Tx Power Low Warning	dBm	-7.3
32-33	Rx Power High Alarm	dBm	2
34-35	Rx Power Low Alarm	dBm	-13.9
36-37	Rx Power High Warning	dBm	-1
38-39	Rx Power Low Warning	dBm	-9.9

Note.

- Alarm /Warming flag is linked to TxFault by default setting.
- Tx Bias Alarm/Warming is describing both prime OSA source. The parentheses value is second source case.

9.5. Digital Diagnostic Monitor Accuracy

The following characteristics are defined over recommended operating conditions.

Parameter	Accuracy	Unit
Internally measured transceiver temperature	+/- 3	deg.C
Internally measured transceiver supply voltage	+/- 3	%
Measured Tx bias current	+/- 10	%
Measured Tx output power	+/- 2	dB
Measured Rx received average optical power	+/- 3	dB

Preliminary

10. RoHS COMPLIANCY

Compliance versus requirements contained inside the following reference document is guaranteed: "Directive 2002/95/EC of 27 January 2003 on the restriction of the use of certain hazardous substances in electrical and electronic equipment from official journal of European Union (European Parliament and of the Council). This product is Compliant at RoHS-6/6 level and contains no leaded solders.

11. Qualification Testing

SPP5200SR-GL-M 10Gb/s transceiver is qualified to Sumitomo Electric Industries internal design and manufacturing standards. Telecordia GR-468-CORE reliability test standards, using methods per MIL-STD-883 for mechanical integrity, endurance, moisture, flammability and ESD thresholds, are followed.

12. Laser Safety Information

SPP5200SR-GL-M transceiver uses a semiconductor laser system that is classified as Class 1 laser products per the Laser Safety requirements of FDA/CDRH, 21 CFR1040.10 and 1040.11. These products have also been tested and certified as Class 1 laser products per IEC 60825-1:2001 International standards.

Caution

If this product is used under conditions not recommended in the specification or is used with unauthorized revision, the classification for laser product safety is invalid. Reclassify the product at your responsibility and take appropriate safety measures.

13. Electromagnetic Compatibility

EMI (Emission)

SPP5200SR-GL-M is designed to meet FCC Class B limits for emissions and noise immunity per CENELEC EN50 081 and 082 specifications.

RF Immunity

SPP5200SR-GL-M has an immunity to operate when tested in accordance with IEC 61000-4-3 (80- 1000MHz, Test Level 3) and GR-1089.

Preliminary

Electrostatic Discharge (ESD) Immunity

SPP5200SR-GL-M has an immunity against direct and indirect ESD when tested accordance with IEC 61000-4-2.

14. Firmware version

This product contains the firmware to control and monitor the module. Sumitomo Electric may upgrade the firmware version without advance notice as far as such would be upper compatible. When customers should prefer to have the current firmware version, Sumitomo Electric will accommodate such request and will assign customized part number for this purpose.

15. Ordering Information

15.1. Part Numbering System

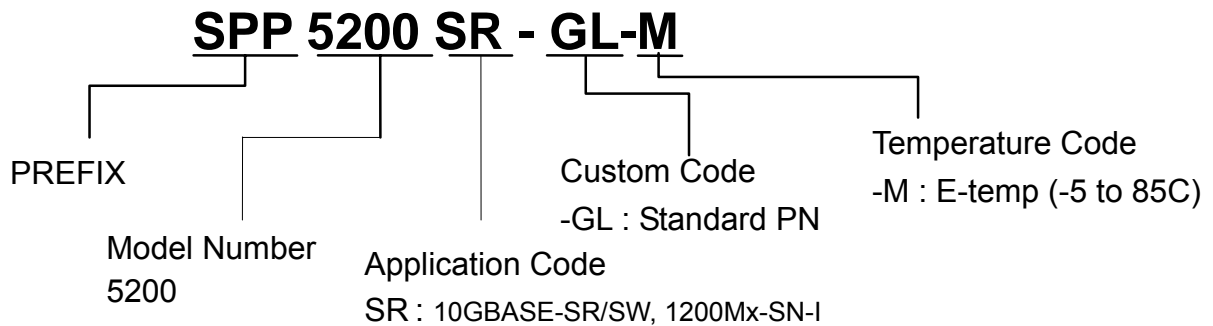

15.2. Ordering Number Code

Table 13-1. SPP5200SR Application Code

Part Number	Temperature Range	Distance	Fiber	E/O	O/E	Telcordia GR-253	ITU-T	IEEE 802.3	ANSI
SPP5200SR-GL-M	-5 to 85 deg.C	300m	MMF	VCSEL 850nm	PIN	-	-	10GBASE-SR	1200-Mx-SN-I

Preliminary

16. Label information (Top label)



17. Contact Information

U.S.A.

Sumitomo Electric Device Innovations, U.S.A., Inc.

<West Coast (USA Headquarters)>

2355 Zanker Rd. San Jose, CA 95131-1138 USA

Tel: +1-408-232-9500

Fax: +1-408-428-9111

<East Coast>

4021 Stirrup Creek Drive, Suite 200, Durham, NC 27703 USA

Tel: +1-919-361-1600

Fax: +1-919-361-1619

Email: information@sei-device.com

<http://www.sei-device.com/>

Europe

Sumitomo Electric Europe Ltd.

220 Centennial Park, Elstree, Herts, WD6 3SL UK

Tel: +44-208-953-8681

Fax: +44-208-207-5950

E-mail: photonics@sumielectric.com

<http://www.sumielectric.com>

Asia

Sumitomo Electrics Asia Ltd.

Photonics Department

Room 2624 - 2637, 26F., Sun Hung Kai Center, 30 Harbour Road, Wanchai, Hongkong.

Tel: +852-2576-0080

Fax: +852-2576-6412

Japan

Sumitomo Electric Industries, Ltd.

Device Sales Department

<Tokyo>

3-9-1, Shibaura, Minato-ku, Tokyo, 108-8539 Japan

TEL +81-3-6722-3286

FAX +81-3-6722-3284

<Osaka>

4-5-33, Kitahama, Chuo-ku, Osaka, 541-0041 Japan

Tel: +81-6-6220-4245

Fax: +81-6-6222-6231

E-mail: optoele-sales-pro-sml@list.sei.jp

<http://www.sei.co.jp/Electro-optic/index.html>