

850nm 10Gb/s XFP Optical Transceiver Modules

SXP3100S_ Family

SXP3100SX: Multi-rate, Commercial Temperature (COM)

SXP3100SN: 8.5GFC, Commercial Temperature (COM)

SXP3100SX-M: Multi-rate, Extended Temperature (EXT)

SXP3100SN-M: 8.5GFC, Extended Temperature (EXT)

Features

- ◆ Commercial Temperature Range -5 to 70C (COM)
- ◆ Extended Temperature Range -5 to 85C (EXT)
- ◆ Multi-Speed (9.95 OIF-VSR, 10.5GFC, IEEE802.3ae 10.3Gb/s, 11.1 Gb/s FEC)
- ◆ 8.5 Gb/s operation (CDR retiming disabled)
- ◆ Low Power Consumption < 1.25W COM, < 1.5W EXT
- ◆ RoHS 6 Compliant to EU Directive 2002/95/EC
- ◆ High sensitivity PIN photo diode and TIA (~ -15 dBm OMA and -11dBm Stressed Sensitivity @ 10-12 BER)
- ◆ No Reference Clock Required
- ◆ Electrical Loopback
- ◆ Low EMI
- ◆ Single +3.3V Power Supply
- ◆ Support of 62.5um and 50um Fiber
- ◆ Can output Rx LOL* (bar) instead of LOS by special request
- ◆ Can set receiver Output Amplitude and Emphasis by special request
- ◆ CL 1 Laser Compliant
- ◆ XFP MSA 4.5 Compliant



Applications

- ◆ Extended Temperature Applications
- ◆ OIF VSR-4 Serial 10G
- ◆ 10G Base-SR/SW 10G Ethernet
- ◆ 1200-Mx-SN-I 10G FC
- ◆ 10GE Ethernet switches and routers
- ◆ 10GE Core routers
- ◆ 10GE SAN applications
- ◆ Inter Rack Connection
- ◆ Proprietary 10 Gb/s high speed data connections

1. General Description

The SXP3100S_ is a family of compact 850nm 10Gb/s optical transceiver modules for serial optical communication applications at ~ 10Gb/s. The SXP3100S_ converts a serial electrical data stream to an optical output signal and an optical input signal to serial electrical data streams. All versions of the SXP3100S_ have high speed serial electrical interfaces fully compliant with XFI specifications and allow FR4 host PCB trace lengths up to 200mm.

The SXP3100S_ is designed for use in a variety of 10Gb/s equipment Ethernet LAN (10.3Gb/s) and FC (10.5Gb/s). By disabling the retiming function the SXP3100SN allows for 8.5GFC operation. The high performance 850nm VCSEL transmitter coupled with a high sensitivity PIN receiver provide superior performance for applications up to 300m. The fully compliant XFP form factor provides high density applications, hot pluggability, easy optical port upgrades and low EMI emission. Additionally with the SXP3100SX-M or SXP3100SN-M versions fully compliant performance is achieved across an extended temperature range of -5 to 85C.

Figure 1

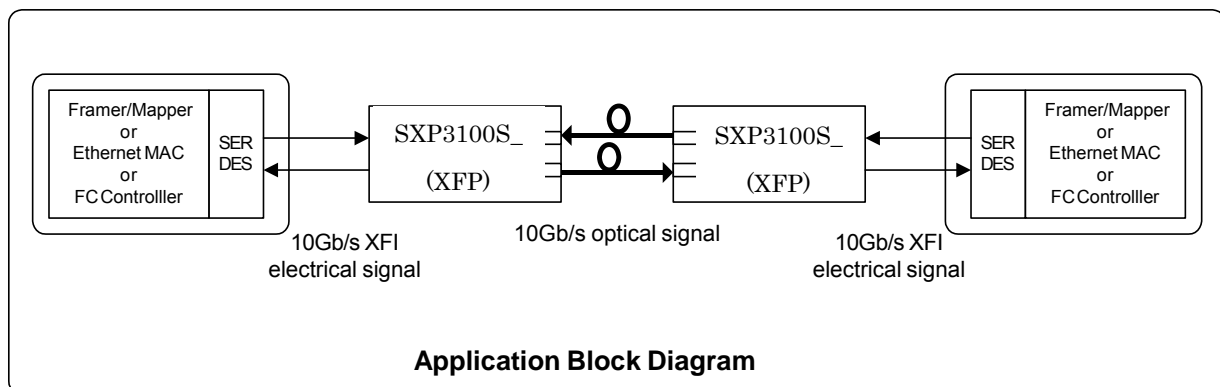

2. Functional Description

The SXP3100S_ contains a duplex LC connector for the optical interface and a 30-pin connector for the electrical interface. Figure 2.1 shows the functional block diagram of SXP3100S_ XFP Transceiver.

2.1 Transmitter Operation

The transceiver module receives 10Gb/s electrical data and transmits the data as an optical signal. The transmitter contains a Clock Data Recovery (CDR) circuit that reduces the jitter of received signal and reshapes the electrical signal before the electrical to optical (E-O) conversion. The optical output power is maintained constant by an automatic power control (APC) circuit. The transmitter output can be turned off by TX disable signal, at TX_DIS pin. When TX_DIS is asserted High, the transmitter is turned off.

2.2 Receiver Operation

The received optical signal is converted to serial electrical data signal. The optical receiver contains a CDR circuits that reshapes and retimes an electrical signal before sending out to the XFI channel (i.e. XFP connector and high speed signal traces).

The RX_LOS signal indicates insufficient optical power for reliable signal reception at the receiver.

2.3 Management Interface

A 2-wire interface (SCL, SDA) is used for serial ID, digital diagnostics and other control /monitor functions. The address of XFP transceiver is 1010000x. MOD_DESEL signal can be used in order to support multiple XFP modules on the same 2-wire interface bus.

3. Mechanical Specifications

Figure 3.1 shows the package dimensions of the SXP3100S_. The SXP3100S_ is complaint with the XFP MSA specification. Package dimensions are specified in section 6.3 of the XFP MSA specification Rev. 4.5.

Figure 3.1. Package dimensions

*Bail color is beige

units: mm

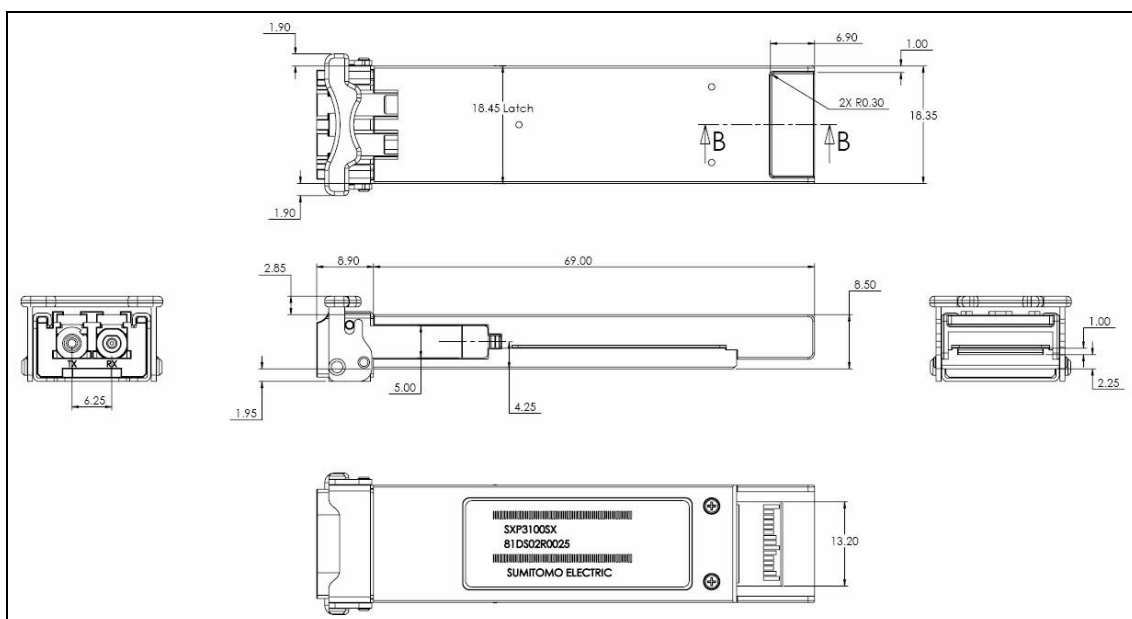

4. Pin Assignment and Pin Description

4.1. XFP Transceiver Electrical Pad Layout

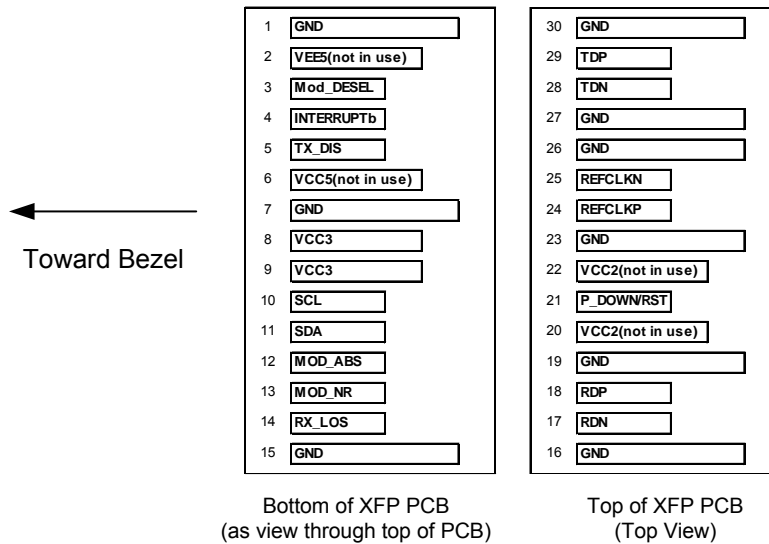

Figure 4.1. XFP Transceiver Electrical Pad Layout

4.2. Host PCB XFP Pinout

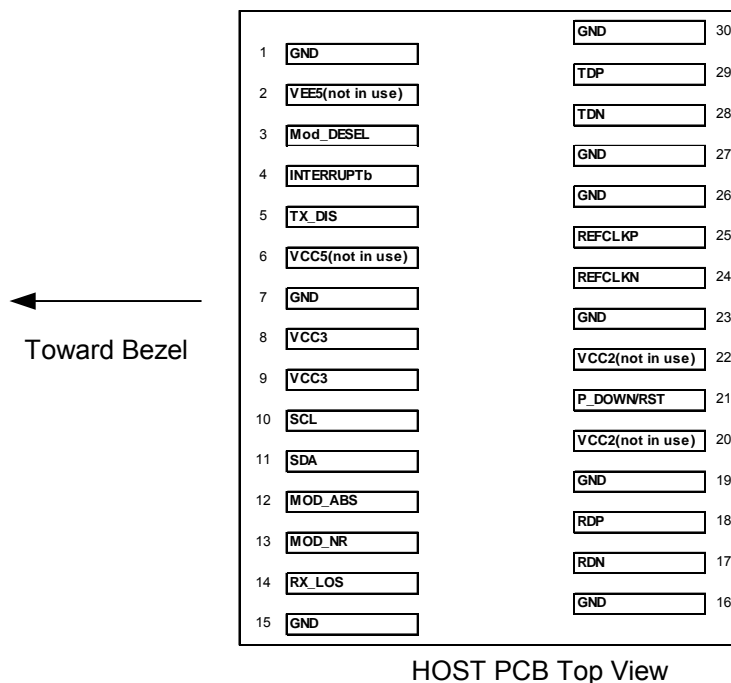

Figure 4.2. Host PCB XFP Pinout

4.3. Pin Descriptions

Table 4.3. Pin Description

Pin#	Name	Logic	Description	Note
1	GND		Module Ground	1
2	VEE5		-5.2V Power Supply , not in use	3
3	MOD_DESEL	LVTTTL-I	Module De-select; When held Low allows module to respond to 2-wire serial interface. When held high the module will not respond or acknowledge the 2-wire serial interface	
4	INTERRUPTb	LVTTTL-O	Indicates presence of an important condition, which can be read over the 2-wire serial interface. This pin is an open collector output and must be pulled up to host_Vcc on the host board.	2
5	TX_DIS	LVTTTL-I	Transmitter Disable; When asserted High, transmitter output is turned off. This pin is pulled up to VCC3 in the module	
6	VCC5		+5V Power Supply, not in use	3
7	GND		Module Ground	1
8	VCC3		+3.3V Power Supply	
9	VCC3		+3.3V Power Supply	
10	SCL	I/O	2-wire serial interface clock. Host shall use a pull-up resistor connected to host_Vcc of +3.3V.	2
11	SDA	I/O	2-wire serial interface data. Host shall use a pull-up resistor connected to host_Vcc of +3.3V.	2
12	MOD_ABS	LVTTTL-O	When high, Indicates the Module is not present	2
13	MOD_NR	LVTTTL-O	Module not ready; When High, Indicates Module Operational Fault and that the module has detected a Fault condition. This pin is an open collector and must be pulled to host_Vcc on the host board.	2,4,
14	RX_LOS	LVTTTL-O	Receiver Loss of Signal; When high, indicates insufficient optical input power to the module. This pin is an open collector and must be pulled to host_Vcc on the host board.	2
15	GND		Module Ground	

Pin#	Name	Logic	Description	Note
16	GND		Module Ground	
17	RDN	CML-O	Receiver Inverted Data Output; AC coupled inside the module.	
18	RDP	CML-O	Receiver Non-Inverted Data Output; AC coupled inside the module.	
19	GND		Module Ground	1
20	VCC2		+1.8V Power Supply; not in use	3
21	P_DOWN/RST	LVTTTL-I	Power down; When High, the module is placed in a limited power mode. Low for normal operation. Reset; The falling edge indicates complete reset of the module. This pin is pulled up to VCC3 in the module.	
22	VCC2		+1.8V Power Supply; not in use	3
23	GND		Module Ground	1
24	REFCLKP	PECL-I	Reference clock Non-Inverted Input; not in use	
25	REFCLKN	PECL-I	Reference clock Inverted Input; not in use	
26	GND		Module Ground	1
27	GND		Module Ground	1
28	TDN	CML-I	Transmitter Inverted Data Input; AC coupled inside the module.	
29	TDP	CML-I	Transmitter Non-Inverted Data Input; AC coupled inside the module.	
30	GND		Module Ground	1

Note

- 1: Module ground pins are isolated from the module case and chassis ground within the module.
- 2: Shall be pulled up with 4.7k to 10k ohm to a voltage between 3.15V and 3.45V on the host board.
- 3: Not connected internally.
- 4: MOD_NR = RX(LOS) or (RX LOL) or (TX LOL) or (Fault)

5. Absolute Maximum Ratings and Recommended Operating Conditions

Table 5.1. Absolute Maximum Ratings SXP3100S_

Parameter	Symbol	Min	Max	Unit	Note
Storage Temperature	Tst	-40	85	degC	
Relative Humidity (non-condensation)	RH	-	85	%	
Supply Voltage	VCC3	-0.5	3.6	V	
Voltage on LVTTTL Input	Vilvttl	-0.5	VCC3+0.5	V	
LVTTTL Output Current	Iolvttl	-	15	mA	
Voltage on Open Collector Output	Voco	0	3.6	V	
Receiver Input Optical Power(Average)	Mip	-	0	dBm	1

Note:

1: PIN Receiver.

Table 5.2. Recommended Operating Conditions and Supply Requirements

Parameter	Symbol	Min	Max	Unit	Note
Relative Humidity (non-condensing)	Rhop	-	85	%	
Power Supply Voltage	VCC3	3.135	3.465	V	1
SXP3100SX, SXP3100SW					
Operating Case Temperature	Topc	-5	70	degC	
Power Supply Current	ICC3	-	360	mA	2
Total Power Consumption	Pd	-	1.25	W	3
SXP3100SX-M, SXP3100SW-M					
Operating Case Temperature	Topc	-5	85	degC	
Power Supply Current	ICC3	-	433	mA	2
Total Power Consumption	Pd	-	1.50	W	3

Note:

1: VCC 2, VCC5 and VCC-5 are unused in the SXP3100S_ family

2: max supply current occurs at max voltage.

3: max power dissipation calculated at worst case condition i.e. max Icc3 at max Vcc3

6. Electrical Interface

6.1. High Speed Electrical Interface

XFI Application Reference model

Figure 6.1.1 shows the high speed electrical interface (XFI) compliance points.

XFI electrical interface is specified for each compliance point in chapter 3 of the XFP MSA specification.

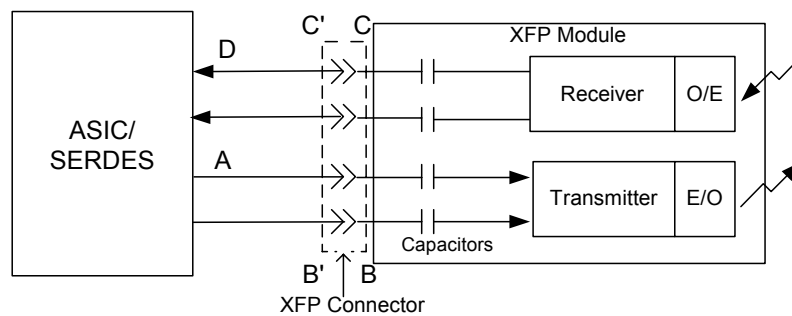

Figure 6.1.1. XFI Application Reference Model

XFI Module Transmitter Input Electrical Interface Specification at B'

Table 6.1.1. XFI Transmitter Input Electrical Specification at B'

Parameter -B'	symbol	Min	Typ	Max	Units	Note
Reference differential Input Impedance	Zd	-	100	-	Ohm	
Termination Mismatch	ΔZ_m	-		5	%	
Input AC Common mode Voltage		-		25	mV(RMS)	
Differential Input Return Loss	SDD11	20		-	dB	1
		8		-	dB	2
		See3		-		3
Comon Mode Input Return Loss	SCC11	3		-	dB	4
Differential to Common Mode Conversion	SCD11	10		-	dB	4
Eye Mask	X1	-		0.305	UI	5
	Y1	60		-	mV	
	Y2	-		410	mV	

Note

1: 0.05 to 0.1 GHz

2: 0.1 to 5.5GHz

3: 5.5 to 12GHz, $SDD11(dB)=8-20.66\log_{10}(f/5.5)$, with f in GHz

4: 0.1 to 15GHz

5: Eye Mask is defined in Figure 6.1.2

XFI Module Receiver Output Electrical Interface Specification at C'

Table 6.1.2 XFI Receiver Output Electrical Specification at C'

Parameter -C'	symbol	Min	Typ	Max	Units	Note
Reference differential Output Impedance	Zd	-	100	-	Ohm	
Termination Mismatch	ΔZ_m	-		5	%	
Output AC Common mode Voltage		-		15	mV(RMS)	
Output Rise and Fall time (20%-80%)	trh, tfh	24		-	ps	
Differential Output Return Loss	SDD22	20		-	dB	1
		8		-	dB	2
		See3		-		3
Comon Mode Input Return Loss	SCC22	3		-	dB	4
Eye Mask	X1	-		0.17	UI	5
	X2	-		0.42	UI	
	Y1	170		-	mV	
	Y2	-		425	mV	

Note

1: 0.05 to 0.1 GHz

2: 0.1 to 5.5GHz

3: 5.5 to 12GHz, $SDD_{11}(dB) = 8 - 20.66 \log_{10}(f/5.5)$, with f in GHz

4: 0.1 to 15GHz

5: Eye Mask is defined in Figure 6.1.3

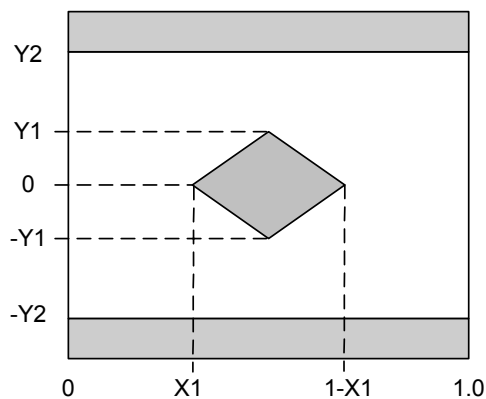

Figure 6.1.2. Transmitter Input Eye Mask

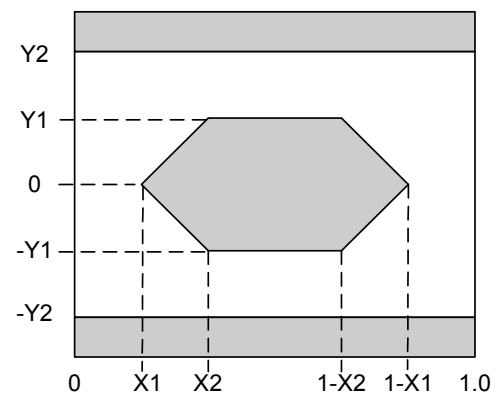

Figure 6.1.3. Receiver Output Eye Mask

XFI Reference Clock

Note that the reference clock is not needed for SXP3100S_. The differential reference clock signals if used are internally terminated across 100ohm resistance as shown in Figure 9.7

6.2. Low speed Electrical Interface

Table 6.3.1. Low Speed Control and Alarm Signals Electrical Interface

Parameter	symbol	Min	Typ	Max	Units	Note
XFP Interrupt, Mod_NR, RX_LOS	Vol	0.0		0.4	V	1
	Voh	Vcc-0.5		Vcc+0.3		2
XFP TX_DIS, P_DOWN/RST	Vil	-0.3		0.8	V	3
	Vih	2.0		VCC3+0.3		4
XFP SCL and SDA Output	Vol	0.0		0.4	V	1
	Voh	Vcc-0.5		Vcc+0.3		2
XFP SCL and SDA Input	Vil	-0.3		VCC3*0.3	V	5
	Vih	VCC3*0.7		VCC3+0.5		6
Capacitance for XFP SCL and SDA I/O pin	Ci	-		14	pF	
Total bus capacitive load for SCL and SDA	Cb	-		100	pF	7
		-		400	pF	8

Note

- 1: Pull-up resistor must be connected to host_Vcc on the host board. Iol(max)=3mA
- 2: Pull-up resistor must be connected to host_Vcc on the host board.
- 3: Pull-up resistor connected to VCC3 within XFP module. Iil(max)= -10μA.
- 4: Pull-up resistor connected to VCC3 within XFP module. Iih(max)= 10μA.
- 5: Pull-up resistor must be connected to host_Vcc on the host board. Iol(max)= -10μA.
- 6: Pull-up resistor must be connected to host_Vcc on the host board. Iol(max)= 10μA.
- 7: at 400KHz, 3.0kohms, at 100kHz 8.0kohms max
- 8: at 400KHz, 0.8kohms, at 100kHz 2.0kohms max

7. Optical Interface

Table 7.1. Optical Interface

Transmitter Parameters	Symbol	Min	Typical	Max	Unit	Note
Operating Data Rate	-	8.5		11.3	Gb/s	1
Output Center Wavelength	l _{tc}	840	850	860	nm	
Spectral Width	dl	-		0.45	nm	
Average Output Power	P _o	-6.5		-1.5	dBm	2
Disabled Power	P _{off}	-		-30	dBm	2
Extinction Ratio	ER	3		-	dB	2
Minimum OMA	OMA			-	dBm	2,4
Transmitter Mask Margin	MM _{tx}	10			%	2
RIN	RIN	-		-128	dB/Hz	
Transmitter Jitter	T _{xj}	per IEEE803.2ae				
Transmitter Dispersion Penalty	TDP			3.9	dB	3
Encircled Flux	<4.5μm			30	%	4
	<19μm	86			%	4
Optical Path Parameter	Symbol	Min	Typical	Max	Unit	Note
Operating Distance		-		300	m	5
Receiver Parameter	Symbol	Min	Typical	Max	Unit	Note
Operating Data Rate	-	8.5		11.3	Gb/s	1
Input Center Wavelength	l _{rc}		850		nm	
Overload	R _{ovl}	3.5		-	dBm	
Minimum Sensitivity	P _{min}	-	-14.5	-11.1	dBm	2
Sensitivity in OMA	OMA ₀	-	-15	-11.1	dBm	2
Stressed Sensitivity in OMA	OMA _{st}	-	-12	-7.5	dBm	2
RX_LOS Assert Level	RLOS _a	-25		-18	dBm	
RX_LOS Deassert Level	RLOS _d	-23.5		-15.5	dBm	
RX_LOS Hysteresis	RLOS _h	0.5		4	dB	
Optical Return Loss	ORL	14		-	dB	
Receiver Eye Mask Margin	MM _{rx}	10		-	dB	2

Notes:

- 1: Data rate tolerance, 10GBASE-SR: typ. +/-100ppm
- 2: Measured at 10.3125Gbps, Non-framed PRBS2³¹-1, NRZ
- 3: Measured into Type A1a (50/125 μm multimode) fiber per ANSI/TIA/EIA-455-203-2.
- 4: Complies with triple tradeoff curves in Table 52-8 of IEEE P802.3ae
- 5: While using 50um, 2000 MHz*.km BW Fiber

8. Electrical and Optical I/O Signal Relationship

Table.8.1. TX_DIS vs. Optical Output Power

TX_DIS	Optical Output Power
Low ($V_{IL} = -0.3$ to $0.8V$)	Enabled
High ($V_{IH} = 2.0$ to $VCC3+0.3V$)	Disabled ($< -30dBm$)

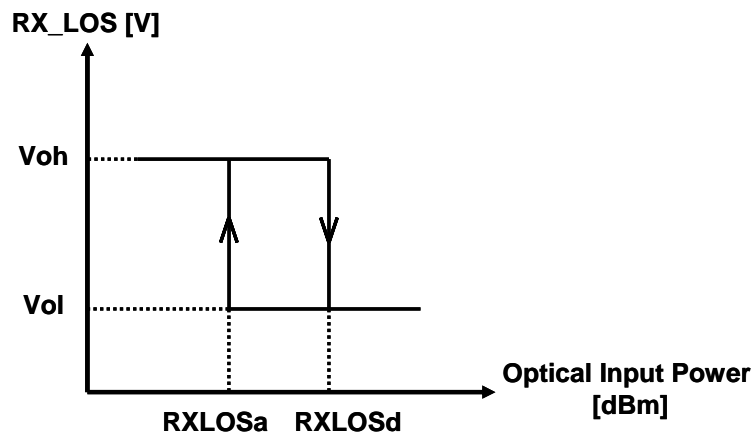

Figure.8.1. Optical Input Power vs. RX_LOS

9. User Interface

9.1. XFP Mechanical Interface

XFP Mechanical Interface is specified in the Chapter 6 in the XFP MSA specification.

XFP Mechanical Components

Figure 9.1 shows the XFP transceiver concept and mechanical components.

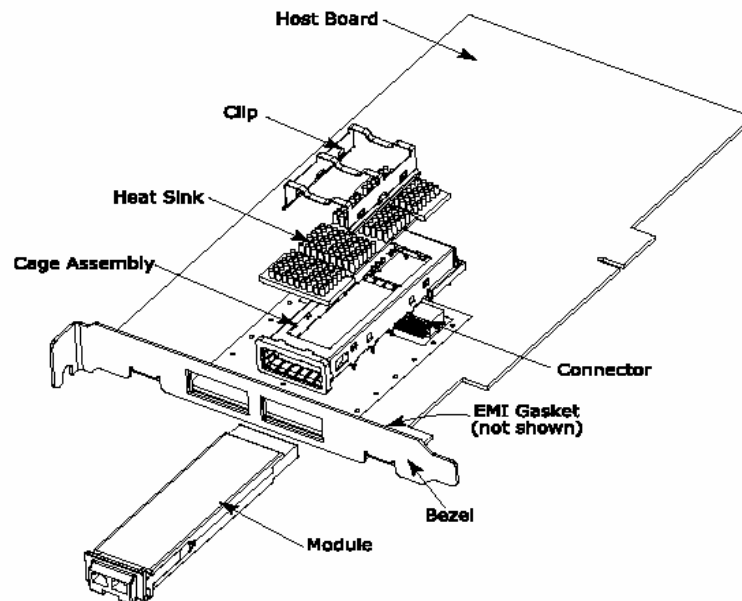

Figure 9.1. XFP Mechanical Interface Concept and Components

XFP Host board Mechanical Layout

XFP Host Board Layout is specified in the Figure 35 of the XFP MSA specification (Rev. 4.5).

Host Board XFP Connector Footprint and Layout

Host board XFP connector layout is specified in the Figure 36 of the XFP MSA Specification (Rev. 4.5).

XFP Datum Alignment and Bezel Design

XFP datum alignment (depth) is specified in the Figure 30 of the XFP MSA specification (Rev. 4.5).

The recommended bezel design is specified in the Figure 37 of the XFP MSA specification (Rev. 4.5).

XFP Connector and XFP Cage Assembly

The XFP 30-contact connector mechanical specification is shown in Figure 39 of the XFP MSA specification (Rev. 4.5).

The XFP Cage Assembly mechanical specification is shown in the Figure 41 of the XFP MSA specification (Rev. 4.5).

9.2. Management Interface

XFP 2-Wire Serial Interface Protocol

XFP 2-wire serial interface is specified in the Chapter 4 of the XFP MSA specification.

The XFP 2-wire serial interface is used for serial ID, digital diagnostics, and certain control functions. The 2-wire serial interface is mandatory for all XFP modules.

The 2-wire serial interface address of the XFP module is 1010000X(A0h). In order to access to multiple modules on the same 2-wire serial bus, the XFP has a MOD_DESEL (module deselect pin). This pin (which is pulled high or deselected in the module) must be held low by the host to select the module of interest and allow communication over 2-wire serial interface. The module must not respond to or accept 2-wire serial bus instructions unless it is selected.

XFP Management Interface

XFP Managed interface is specified in the Chapter 5 of the XFP MSA specification.

The Figure 9.2 shows the structure of the memory map. The normal 256 Byte address space is divided into lower and upper blocks of 128 Bytes. The lower block of 128 Byte is always directly available and is used for the diagnostics and control functions that must be accessed repeatedly. Multiple blocks of memories are available in the upper 128 Bytes of the address space. These are individually addressed through a table select Byte which the user enters into a location in the lower address space. The upper address space tables are used for less frequently accessed functions and control space for future standards definition.

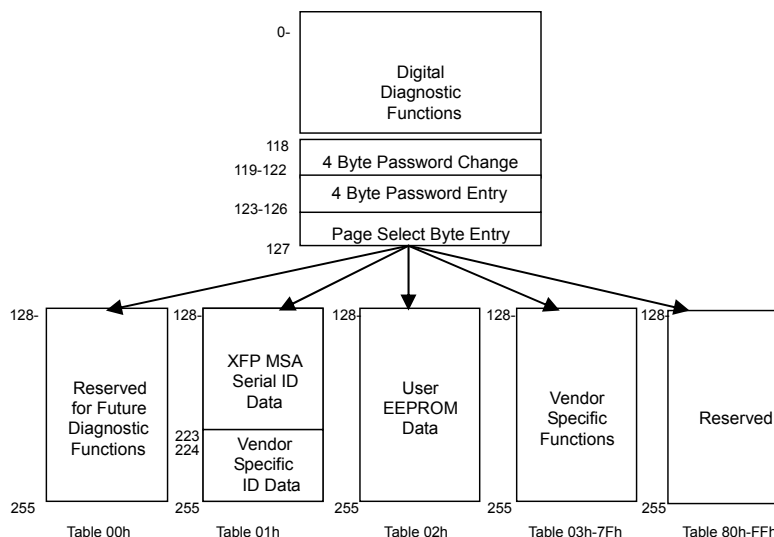

Figure 9.2. 2-wire Serial Interface Memory Map

9.3. A/D Accuracy and Values

Table 9.3.1. A/D Accuracy

Data Address	Parameter	Accuracy	Relative accuracy	Units Display	Note
96-97	Temperature	+/-3degC	NA	Signed 2's complement integer degC	Junction temperature of monitoring IC.
98-99	Reserved				
100-101	Tx Bias	+/-10%	NA	×2μA	Specified by nominal value
102-103	Tx Power	+/-2dB@BOL (Note1) (-6 to +0.5dBm)	+/-1dB (Note2)	×0.1μW	Average Power
104-105	Rx Power	+/-2dB@BOL (Note1) (-15 to +0.5dBm)	+/-1dB (Note2)	×0.1μW	At specified transmitter wavelength.
106-107	Vcc3	+/-3%	NA	×100μV	3.3V Only

Table 9.3.2. A/D Values

Byte	Bit	Name	Description
96	All	Temperature MSB	Signed 2's complement integer temperature (-40 to +125degC) based on internal temperature measurement
97	All	Temperature LSB	Fractional part of temperature(count/256)
98-99	All		Reserved
100	All	Tx Bias MSB	Measured Laser Bias Current in mA. Bias current is full 16 bit value *2uA. (Full range of 0 to 131mA)
101	All	Tx Bias LSB	
102	All	Tx Power MSB	Measured Tx output power in mW. Tx power is full 16 bit value *0.1uW. (Full range of -40 to +8.2dBm)
103	All	Tx Power LSB	
104	All	Rx Power MSB	Measured Rx input power in mW. Tx power is full 16 bit value *0.1uW. (Full range of -40 to +8.2dBm)
105	All	Rx Power LSB	
106	All	Vcc3 MSB	Internally measured transceiver supply voltage. Vcc is full 16 bit value*100uV. (Full range of 0 to +6.55 Volts)
107	All	Vcc3 LSB	
108	All	AUX 2 MSB	Reserved
109	All	AUX 2 LSB	

Note1. As specified by SFF-8472 Rev 9.5

Note2. Over specified temperature and voltage range over the life of the product into a fixed measurement system

9.4. Serial ID Memory Map (Data Field – Page 01h)

Table 9.4.1. SXP3100SX, (SXP3100SX-M)

Address	Size (Bytes)	Name	Data (Hex)	Data (Dec)	Value (ASC)	Description
Base ID Filed						
128	1	Identifier	6	6	06	XFP module
129	1	Ext. Identifier	10	16		1.5W Max
						With CDR
						Tx Clk Not Required
						No CLEI Code
130	1	Connector	7	07		LC Connector
131	8	Transceiver Type	88	136		10GBASE-SR/SW
132			80	128		1200-MX-SN-I
133			0	0		
134			0	0		
135			0	0		
136			0	0		
137			0	0		
138			0	0		
139	1	Encoding	F0	240		64B/66B_NRZ
140	1	BR-Min	63	99		9.95Gbps
141	1	BR-Max	6F	111		11.1Gbps
142	1	Length (SMF)-km	0	0		
143	1	Length (E-50 μm)	96	150		300m
144	1	Length (50 μm)	64	100		100m
145	1	Length (62.5 μm)	21	33		33m
146	1	Length (Copper)	0	0		
147	1	Device Tech	0	0		850nm VCSEL
148	16	Vendor name	53	83	S	
149			75	117	u	
150			6D	109	m	
151			69	105	i	
152			74	116	t	
153			6F	111	o	
154			6D	109	m	
155			6F	111	o	
156			45	69	E	
157			6C	108	l	
158			65	101	e	
159			63	99	c	
160			74	116	t	
161			72	114	r	
162			69	105	i	
163			63	99	c	
164	1	CDR Support	F9	249		9.9,10.3,10.5,10.7,11.1, XFI Looback
165	3	Vendor OUI	0	00		
166			0	00		
167			5F	95		
168	16	Vendor PN	53	83	S	
169			58	88	X	
170			50	80	P	
171			33	51	3	
172			31	49	1	
173			30	48	0	
174			30	48	0	
175			53	83	S	
176			58	88	X	
177			20 (2D)	32 (45)	(-)	
178			20 (4D)	32 (77)	(M)	
179			20	32		
180			20	32		
181			20	32		
182			20	32		
183			20	32		
184	2	Vendor rev	4E	78	N	Variable
185	2	Wavelength	20	32		
186			42	66		850nm
187	2	Wavelength Tolerance	68	104		
188			7	7		+/-10 nm (Note1)
189	1	Max Case Temp	D0	208		
190			46 (55)	70 (85)		70degC (85degC)
191	1	CC_BASE				



Address	Size (Bytes)	Name	Data (Hex)	Data (Dec)	Value (ASC)	Description
Extended ID Field						
192	4	Power Supply	4B	75		Max Power 1.5W
193			96	150		Power Down 1.5W Note3
194			4	4		Max Icc on Vcc3 500mA Note4
195			0	0		Max Icc on 5, 1.8 &-5.2V= 0 mA Note 4
196	16	Vendor SN	Note6	Note6		
197						
198						
199						
200						
201						
202						
203						
204						
205						
206						
207	8	Date Code	Note7	Note7		Year
208						Year
209						Month
210						Month
211						Day
212						Day
213						Module Lot Code 1
214						Module Lot Code 2
215	1	Diagnostic Monitoring	8	08		No BER Support
216						Average Power
217	1	Enhanced Options	60	96		Optional Soft TX_Disable
218						Optional Soft P_down
219	1	Aux Monitoring	70	112		+3.3V Support Voltage
220						Auxiliary monitoring not implemented
221	1	CC_EXT	Note8	Note8		Note8
Vendor Specific ID Fields						
222	32	Vendor Specific	0	0		
223			0	0		
224			0	0		
225			0	0		
226			0	0		
227			0	0		
228			0	0		
229			0	0		
230			0	0		
231			0	0		
232			0	0		
233			0	0		
234			0	0		
235			0	0		
236			0	0		
237			0	0		
238			0	0		
239			0	0		
240			0	0		
241			0	0		
242			0	0		
243			0	0		
244			0	0		
245			0	0		
246			0	0		
247			0	0		
248			0	0		
249			0	0		
250			0	0		
251			0	0		
252			0	0		
253			0	0		
254	0	0				
255	0	0				

Note1. The guaranteed +/- range of transmitter output wavelength under all normal operating conditions.

Note2. Address 191 is check sum of bytes 128 to 190.

Note3. Maximum total power dissipation in power down mode

Note4 &5 . +5V, 1.8V and -5.2V Supplies are not used

Note6. Address 196 to 211 Vendor Serial Number

Note7. Address 212 to 219 Date code

Note8. Address 223 is check sum of bytes 192 to 222

Table 9.4.1. SXP3100SN, (SXP3100SN-M)

Address	Size (Bytes)	Name	Data (Hex)	Data (Dec)	Value (ASC)	Description
Base ID Filed						
128	1	Identifier	6	6	06	XFP module
129	1	Ext. Identifier	30	48		1.5W Max
						No CDR
						Tx Clk Not Required
						No CLEI Code
130	1	Connector	7	07		LC Connector
131	8	Transceiver Type	0	0		
132			0	0		
133			0	0		
134			0	0		8xFC MMF
135			0	0		
136			0	0		
137			0	0		
138			0	0		
139	1	Encoding	F0	240		64B/66B, NRZ
140	1	BR-Min	55	85		8.5 GB/s
141	1	BR-Max	55	85		8.5 GB/s
142	1	Length (SMF)-km	0	0		
143	1	Length (E-50 μm)	96	150		300m
144	1	Length (50 μm)	64	100		100m
145	1	Length (62.5 μm)	21	33		33m
146	1	Length (Copper)	0	0		
147	1	Device Tech	0	0		850nm VCSEL
148	16	Vendor name	53	83	S	
149			75	117	u	
150			6D	109	m	
151			69	105	i	
152			74	116	t	
153			6F	111	o	
154			6D	109	m	
155			6F	111	o	
156			45	69	E	
157			6C	108	l	
158			65	101	e	
159			63	99	c	
160			74	116	t	
161			72	114	r	
162			69	105	i	
163			63	99	c	
164	1	CDR Support	1	1		XFI LoopBack
165	3	Vendor OUI	0	00		
166			0	00		
167			5F	95		
168	16	Vendor PN	53	83	S	
169			58	88	X	
170			50	80	P	
171			33	51	3	
172			31	49	1	
173			30	48	0	
174			30	48	0	
175			53	83	S	
176			4E	78	N	
177			20 (2D)	32 (45)	(-)	
178			20 (4D)	32 (77)	(M)	
179			20	32		
180			20	32		
181			20	32		
182			20	32		
183			20	32		
184	2	Vendor rev	4E	78	N	Variable
185			20	32		
186	2	Wavelength	42	66		850nm
187			68	104		
188	2	Wavelength Tolerance	7	7		+/-10 nm (Note1)
189			D0	208		
190	1	Max Case Temp	46 (55)	70 (85)		70degC (85degC)
191	1	CC BASE	Note8	Note8		Note 8



Address	Size (Bytes)	Name	Data (Hex)	Data (Dec)	Value (ASC)	Description
Extended ID Field						
192	4	Power Supply	4B	75		Max Power 1.5W
193			96	150		Power Down 1.5W Note3
194			4	4		Max Icc on Vcc3 500mA Note4
195			0	0		Max Icc on 5, 1.8 &-5.2V= 0 mA Note 4
196	16	Vendor SN	Note6	Note6		
197						
198						
199						
200						
201						
202						
203						
204						
205						
206						
207	8	Date Code	Note7	Note7		Year
208						Year
209						Month
210						Month
211						Day
212						Day
213						Module Lot Code 1
214						Module Lot Code 2
215	1	Diagnostic Monitoring	8	08		No BER Support
216						Average Power
217	1	Enhanced Options	60	96		Optional Soft TX_Disable
218						Optional Soft P_down
219	1	Aux Monitoring	70	112		+3.3V Support Voltage
220						Auxiliary monitoring not implemented
221	1	CC_EXT	Note 8	Note 8		Note 8
Vendor Specific ID Fields						
222	32	Vendor Specific	0	0		
223			0	0		
224			0	0		
225			0	0		
226			0	0		
227			0	0		
228			0	0		
229			0	0		
230			0	0		
231			0	0		
232			0	0		
233			0	0		
234			0	0		
235			0	0		
236			0	0		
237			0	0		
238			0	0		
239			0	0		
240			0	0		
241			0	0		
242			0	0		
243			0	0		
244			0	0		
245			0	0		
246			0	0		
247			0	0		
248			0	0		
249			0	0		
250			0	0		
251			0	0		
252			0	0		
253			0	0		
254	0	0				
255	0	0				

-
- Note1. The guaranteed +/- range of transmitter output wavelength under all normal operating conditions.
 - Note2. Address 191 is check sum of bytes 128 to 190.
 - Note3. Maximum total power dissipation in power down mode
 - Note4. +5V, 1.8V and -5.2V Supplies are not used
 - Note6. Address 196 to 211 Vendor Serial Number
 - Note7. Address 212 to 219 Date code
 - Note8. Address 223 is check sum of bytes 192 to 222

9.5. Table 0 memory map: Alarm and Warning Thresholds

9.5.1 SXP3100SX and SXP3100SN Commercial Temperature Transceivers:

Address	Data (Hex)	Name of field	Limit	Unit
2	4E	Temp High Alarm (MSB)	78.0	C
3	0	Temp High Alarm (LSB)		
4	F3	Temp Low Alarm (MSB)	-13.0	C
5	0	Temp Low Alarm (LSB)		
6	49	Temp High Warn (MSB)	73.0	C
7	0	Temp High Warn (LSB)		
8	F8	Temp Low Warn (MSB)	-8.0	C
9	0	Temp Low Warn (LSB)		
10 - 17	0	Reserved		
18	13	I Bias High Alarm (MSB)	10.0	mA
19	6F	I Bias High Alarm (LSB)		
20	2	I Bias Low Alarm (MSB)	1.0	mA
21	0	I Bias Low Alarm (LSB)		
22	11	I Bias High Warn (MSB)	9.0	mA
23	7D	I Bias High Warn (LSB)		
24	5	I Bias Low Warn (MSB)	3.0	mA
25	C3	I Bias Low Warn (LSB)		
26	31	Tx Power High Alarm (MSB)	1259.0	uW
27	2E	Tx Power High Alarm (LSB)		
28	6	Tx Power Low Alarm (MSB)	158.6	uW
29	32	Tx Power Low Alarm (LSB)		
30	27	Tx Power High Warn (MSB)	1000.0	uW
31	10	Tx Power High Warn (LSB)		
32	6	Tx Power Low Warn (MSB)	178.0	uW
33	F4	Tx Power Low Warn (LSB)		
34	31	Rx Power High Alarm (MSB)	1259.0	uW
35	2E	Rx Power High Alarm (LSB)		
36	1	Rx Power Low Alarm (MSB)	31.3	uW
37	39	Rx Power Low Alarm (LSB)		
38	27	Rx Power High Warn (MSB)	1000.0	uW
39	10	Rx Power High Warn (LSB)		
40	2	Rx Power Low Warn (MSB)	61.0	uW
41	62	Rx Power Low Warn (LSB)		
42	8D	AUX1 High Alarm (MSB)	3.63	V
43	9A	AUX1 High Alarm (LSB)		
44	73	AUX1 Low Alarm (MSB)	2.97	V
45	D2	AUX1 Low Alarm (LSB)		
46	8B	AUX1 High Warn (MSB)	3.56	V
47	0	AUX1 High Warn (LSB)		
48	76	AUX1 Low Warn (MSB)	3.04	V
49	96	AUX1 Low Warn (LSB)		
50	0	AUX2 High Alarm (MSB)	0.00	V
51	0	AUX2 High Alarm (LSB)		
52	0	AUX2 Low Alarm (MSB)	0.00	V
53	0	AUX2 Low Alarm (LSB)		
54	0	AUX2 High Warn (MSB)	0.00	V
55	0	AUX2 High Warn (LSB)		
56	0	AUX2 Low Warn (MSB)	0.00	V
57	0	AUX2 Low Warn (LSB)		

9.5.2 SXP3100SX-M and SXP3100SN-M, Extended Temperature Transceivers

Address	Data (Hex)	Name of field	Limit	Unit
2	4E	Temp High Alarm (MSB)	93.0	C
3	0	Temp High Alarm (LSB)		
4	F3	Temp Low Alarm (MSB)	-13.0	C
5	0	Temp Low Alarm (LSB)		
6	49	Temp High Warn (MSB)	88.0	C
7	0	Temp High Warn (LSB)		
8	F8	Temp Low Warn (MSB)	-8.0	C
9	0	Temp Low Warn (LSB)		
10 - 17	0	Reserved		
18	13	I Bias High Alarm (MSB)	11.0	mA
19	6F	I Bias High Alarm (LSB)		
20	2	I Bias Low Alarm (MSB)	1.0	mA
21	0	I Bias Low Alarm (LSB)		
22	11	I Bias High Warn (MSB)	10.0	mA
23	7D	I Bias High Warn (LSB)		
24	5	I Bias Low Warn (MSB)	3.0	mA
25	C3	I Bias Low Warn (LSB)		
26	31	Tx Power High Alarm (MSB)	1259.0	uW
27	2E	Tx Power High Alarm (LSB)		
28	6	Tx Power Low Alarm (MSB)	158.6	uW
29	32	Tx Power Low Alarm (LSB)		
30	27	Tx Power High Warn (MSB)	1000.0	uW
31	10	Tx Power High Warn (LSB)		
32	6	Tx Power Low Warn (MSB)	178.0	uW
33	F4	Tx Power Low Warn (LSB)		
34	31	Rx Power High Alarm (MSB)	1259.0	uW
35	2E	Rx Power High Alarm (LSB)		
36	1	Rx Power Low Alarm (MSB)	31.3	uW
37	39	Rx Power Low Alarm (LSB)		
38	27	Rx Power High Warn (MSB)	1000.0	uW
39	10	Rx Power High Warn (LSB)		
40	2	Rx Power Low Warn (MSB)	61.0	uW
41	62	Rx Power Low Warn (LSB)		
42	8D	AUX1 High Alarm (MSB)	3.63	V
43	9A	AUX1 High Alarm (LSB)		
44	73	AUX1 Low Alarm (MSB)	2.97	V
45	D2	AUX1 Low Alarm (LSB)		
46	8B	AUX1 High Warn (MSB)	3.558	V
47	0	AUX1 High Warn (LSB)		
48	76	AUX1 Low Warn (MSB)	3.036	V
49	96	AUX1 Low Warn (LSB)		
50	0	AUX2 High Alarm (MSB)	0.00	V
51	0	AUX2 High Alarm (LSB)		
52	0	AUX2 Low Alarm (MSB)	0.00	V
53	0	AUX2 Low Alarm (LSB)		
54	0	AUX2 High Warn (MSB)	0.00	V
55	0	AUX2 High Warn (LSB)		
56	0	AUX2 Low Warn (MSB)	0.00	V
57	0	AUX2 Low Warn (LSB)		

9.6. Recommended Supply filter

Figure 9.6. Supply Filter

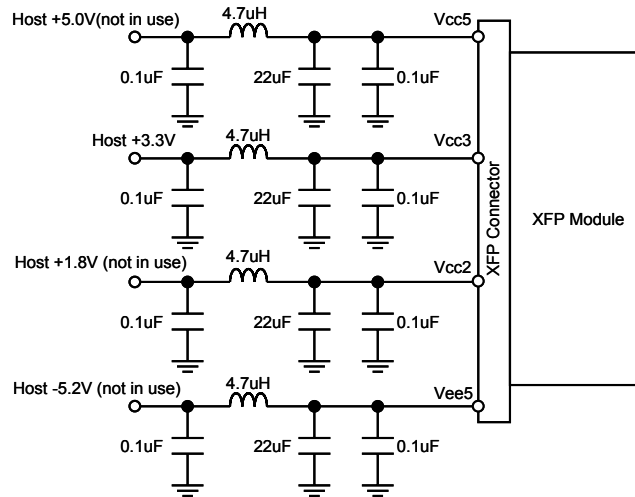

9.7 Recommended Electrical Interface

Figure 9.7. Recommended Electrical Interface

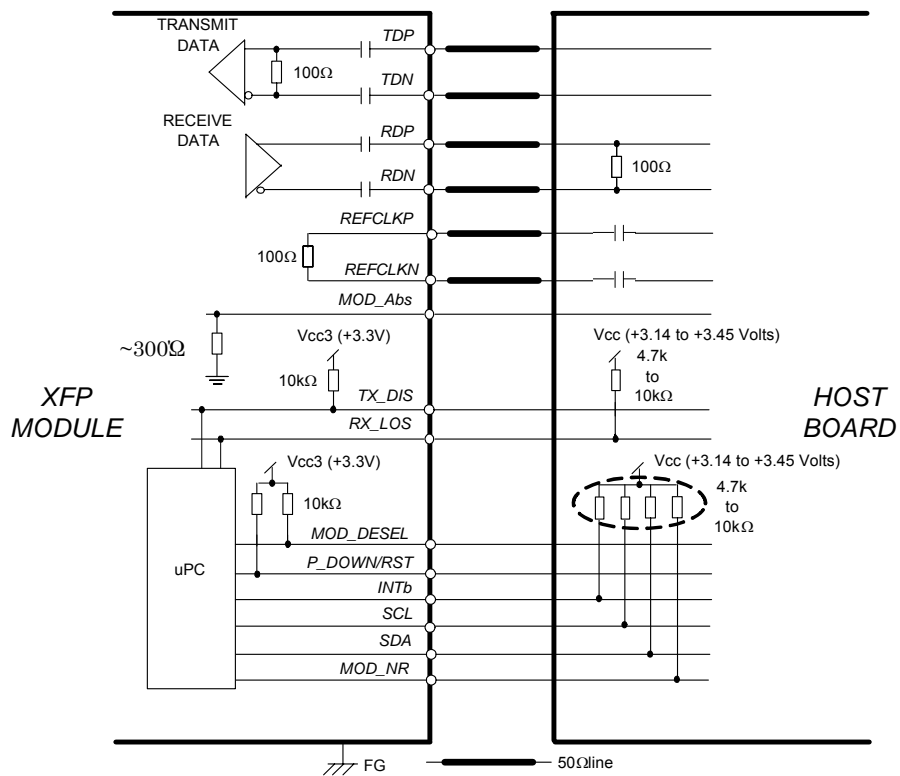

10. Qualification Testing

The SXP3100S_ will be qualified to Sumitomo Electric Industries internal design and manufacturing standards. Telecordia GR-468-CORE reliability test standards, using methods per MIL-STD-883 for mechanical integrity, endurance, moisture, flammability and ESD thresholds, will be followed. RoHS compliance testing to follow JESD201. (Qualification Date Pending)

11. Laser Safety Information

The SXP3100S_ 10Gb/s XFP transceiver is a Class 1 Laser product. The SXP3100S_ uses a semiconductor laser system that is classified as Class 1 per the Laser Safety requirements as defined by the FDA/CDRH, 21, CFR1040.10 and 1040.11. These products are also tested and certified according to IEC 60825-1:2001 International standards.

Caution

If this product is used under conditions not recommended in the specification or is used with unauthorized revision, the classification for laser product safety is invalid. Reclassify the product at your responsibility and take appropriate safety measures.

12. Electromagnetic Compatibility (Pending)

EMI (Emission)

The SXP3100S_ is designed to meet FCC Class B limits for emissions and noise immunity per CENELEC EN50 081 and 082 specifications.

RF Immunity

The SXP3100S_ has an immunity to operate when tested in accordance with IEC 61000-4-3 (80- 1000MHz, Test Level 3) and GR-1089.

Electrostatic Discharge (ESD) Immunity

The SXP3100S_ has an immunity against direct and indirect ESD when tested accordance with IEC 61000-4-2.

13. RoHS COMPLIANCE

Compliance versus requirements contained within the following reference document is guaranteed: “Directive 2002/95/EC of the European Parliament and of the Council of 27 January 2003 on the restriction of the use of certain hazardous substances in electrical and electronic equipment” (RoHS Directive)”. This product will be compliant to the EU RoHS 6 environmental requirements **and contains no leaded solders**.

14.0. Part Numbering System

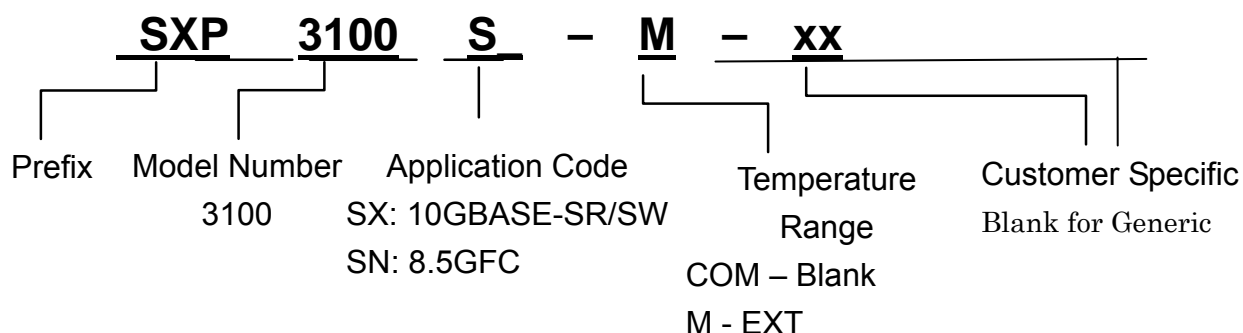

14.1. Evaluation Board Kit

For test purposes, Evaluation Board model number SK3101A and SP3101A may be ordered to use with the SXP3100S_ Series transceivers.

- SK3101A : SPX3101 XFP evaluation board
- SP3101A : XFP 2-wire serial interface evaluation kit

14.2. Ordering Number Code

- SXP3100SX Multirate, 850nm VCSEL, PIN-PD, RoHS-6, COM
- SXP3100SN 8.5GFC, 850nm VCSEL, PIN-PD, RoHS-6, COM
- SXP3100SX-M Multirate, 850nm VCSEL, PIN-PD, RoHS-6, EXT
- SXP3100SN-M 8.5GFC, 850nm VCSEL, PIN-PD, RoHS-6, EXT

14.3 Firmware version

This product contains firmware inside. Sumitomo Electric may upgrade the firmware version without advance notice as far as such would be upper compatible. When customer should prefer to have the current firmware version, Sumitomo Electric will accommodate such request and will assign customized part number for this purpose.

14.4. I2C Interface

If the serial clock (SCL) is more than 100kHz, the SCL is held in line low (clock stretching) during an I2C read or write operation.

15. Contact Information

U.S.A.

Sumitomo Electric Device Innovations, U.S.A., Inc.

<West Coast (USA Headquarters)>

2355 Zanker Rd. San Jose, CA 95131-1138, USA

Tel: +1-408-232-9500

Fax: +1-408-428-9111

<East Coast>

4021 Stirrup Creek Drive, Suite 200, Durham, NC 27703, USA

Tel: +1-919-361-1600

Fax: +1-919-361-1619

Email: information@sei-device.com

<http://www.sei-device.com/>

Europe

Sumitomo Electric Europe Ltd.

220 Centennial Park, Elstree, Herts, WD6 3SL UK

Tel: +44-208-953-8681

Fax: +44-208-207-5950

E-mail: photonics@sumielectric.com

<http://www.sumielectric.com>

Asia

Sumitomo Electrics Asia Ltd.

Photonics Department

Room 2624 - 2637, 26F., Sun Hung Kai Center, 30 Harbour Road, Wanchai, Hongkong.

Tel: +852-2576-0080

Fax: +852-2576-6412

Japan

Sumitomo Electric Industries, Ltd.

Device Sales Department

<Tokyo>

3-9-1, Shibaura, Minato-ku, Tokyo 108-8539, Japan

TEL +81-3-6722-3286

FAX +81-3-6722-3284

<Osaka>

4-5-33, Kitahama, Chuo-ku, Osaka 541-0041, Japan

Tel: +81-6-6220-4245

Fax: +81-6-6222-6231

E-mail: optoele-sales-pro-sml@list.sei.jp

<http://www.sei.co.jp/products/index.html>