

## 10Gb/s XFP Optical Transceiver Module

### SXP3101EX-03

( 10GBASE-ER/EW, 1550nm EML, PIN-PD)

#### Features

- ◆ 10Gb/s Serial Optical Interface
  - High quality and reliability optical device and sub-assemblies
  - 1550nm EML for up to 40km over single mode fiber
  - High sensitivity PIN photo diode and TIA
- ◆ XFP MSA Revision 4.0 Compliant
  - Easy supply management for hot pluggability
  - Duplex LC Receptacle
  - XFP Mechanical Interface with color coded bail latch for easy removal (Bail color: Red)
  - XFI High Speed Electrical Interface
  - 2-wire interface for management and diagnostic monitor
  - Tx\_Disable and Rx\_LOS functions
- ◆ Protocol
  - IEEE802.3ae 10 Gigabit Ethernet
- ◆ Low Power Consumption
  - 3.3V and +5.0V power supply
  - Power consumption less than 3.5W



#### Applications

- ◆ 10GE Etheswitches and routers
- ◆ 10GE Core-routers
- ◆ 10GE Storage
- ◆ Inter Rack Connection
- ◆ Other high speed data connections

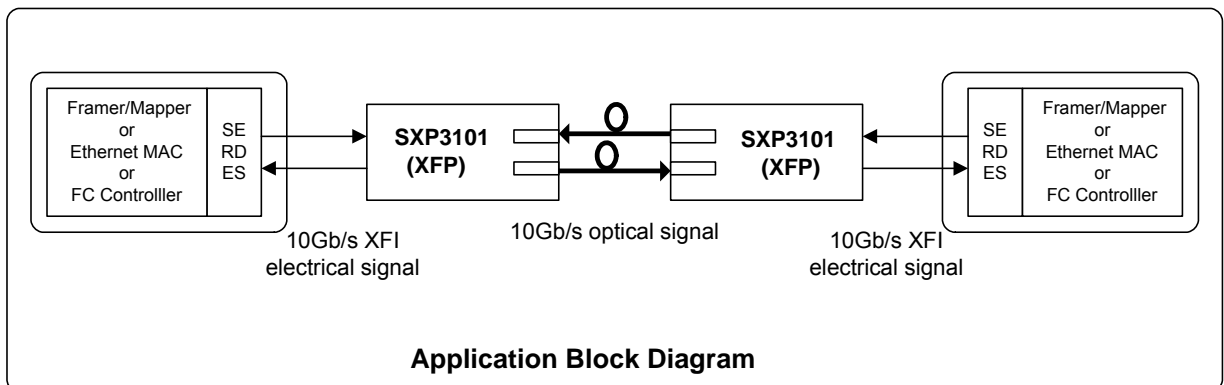

## 1. General Description

The SXP3101EX-03 is a very compact 10Gb/s optical transceiver module for serial optical communication applications at 10Gb/s. The SXP3101EX-03 converts a 10Gb/s serial electrical data stream to 10Gb/s optical output signal and a 10Gb/s optical input signal to 10Gb/s serial electrical data streams. The high speed 10Gb/s electrical interface is fully compliant with XFI specification.

The SXP3101EX-03 is designed for Ethernet LAN (10.3Gb/s) and WAN (9.95Gb/s) applications. The high performance cooled 1550nm EML transmitter and high sensitivity PIN receiver provide superior performance for Ethernet applications at up to 40km links.

The fully XFP compliant form factor provides hot pluggability, easy optical port upgrades and low EMI emission.

## 2. Functional Description

The SXP3101EX-03 contains a duplex LC connector for the optical interface and a 30-pin connector for the electrical interface. Figure 2.1. shows the functional block diagram of SXP3101EX-03 XFP Transceiver.

### Transmitter Operation

The transceiver module receives 10Gb/s electrical data and transmits the data as an optical signal. The transmitter contains a Clock Data Recovery (CDR) circuit that reduces the jitter of received signal and reshapes the electrical signal before the electrical to optical (E-O) conversion. The optical output power is maintained constant by an automatic power control (APC) circuit. The transmitter output can be turned off by Tx disable signal, TX\_DIS pin. When TX\_DIS is asserted high, transmitter is turned off.

### Receiver Operation

The received optical signal is converted to serial electrical data signal. The optical receiver contains a CDR circuits that reshapes and retimes an electrical signal before sending out to the XFI channel (i.e. XFP connector and high speed signal traces).

The RX\_LOS signal indicates insufficient optical power for reliable signal reception at the receiver.

### Management Interface

A 2-wire interface (SCL, SDA) is used for serial ID, digital diagnostics and other control /monitor functions. The address of XFP transceiver is 1010000x. MOD\_DESEL signal can be used in order to support multiple XFP modules on the same 2-wire interface bus.



## 4. Pin Assignment and Pin Description

### 4.1. XFP Transceiver Electrical Pad Layout

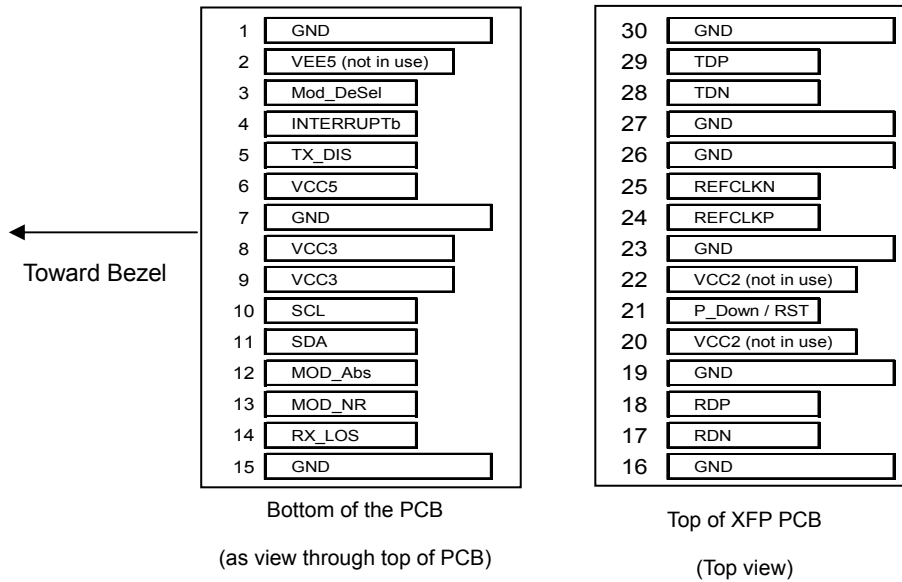

Figure 4.1. XFP Transceiver Electrical Pad Layout

### 4.2. Host PCB XFP Pinout

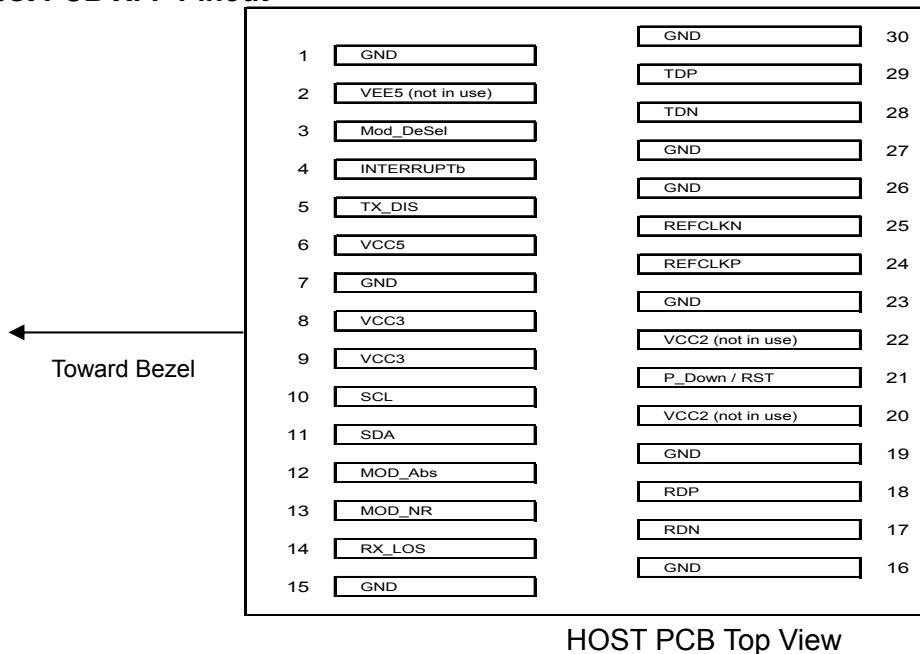

Figure 4.2. Host PCB XFP Pinout

### 4.3. Pin Descriptions

**Table 4.3. Pin Description**

Pin#	Name	Logic	Description	Note
1	GND	LVTTL-I	Module Ground	1
2	VEE5		-5.2V Power Supply; <b>not in use</b>	3
3	MOD_DeSel	LVTTL-I	Module De-select; When held Low allows module to respond to 2-wire serial interface	
4	INTERRUPTb	LVTTL-O	Indicates presence of an important condition, which can be read over the 2-wire serial interface. This pin is an open collector output and must be pulled up to host_Vcc on the host board.	2
5	TX_DIS	LVTTL-I	Transmitter Disable; When asserted High, transmitter output is turned off. This pin is pulled up to VCC3 in the module	
6	VCC5		+5V Power Supply,	
7	GND		Module Ground	1
8	VCC3		+3.3V Power Supply	
9	VCC3		+3.3V Power Supply	
10	SCL	I/O	2-wire serial interface clock. Host shall use a pull-up resistor connected to host_Vcc of +3.3V.	2
11	SDA	I/O	2-wire serial interface data. Host shall use a pull-up resistor connected to host_Vcc of +3.3V.	2
12	MOD_Abs	LVTTL-O	Indicates Module is not present. Host shall pull up this pin, and grounded in the module. "High" when the XFP module is absent from a host board.	2
13	MOD_NR	LVTTL-O	Module not ready; When High, Indicates Module Operational Fault. This pin is an open collector and must be pulled to host_Vcc on the host board.	2
14	RX_LOS	LVTTL-O	Receiver Loss of Signal; When high, indicates insufficient optical input power to the module. This pin is an open collector and must be pulled to host_Vcc on the host board.	2
15	GND		Module Ground	

Pin#	Name	Logic	Description	Note
16	GND		Module Ground	
17	RDN	CML-O	Receiver Inverted Data Output; AC coupled inside the module.	
18	RDP	CML-O	Receiver Non-Inverted Data Output; AC coupled in side the module.	
19	GND		Module Ground	1
20	VCC2		+1.8V Power Supply; <b>not in use</b>	3
21	P_Down/RST	LVTTTL-I	Power down; When High, module is limited power mode. Low for normal operation. Reset; The falling edge indicates complete reset of the module. This pin is pulled up to VCC3 in the module.	
22	VCC2		+1.8V Power Supply; <b>not in use</b>	3
23	GND		Module Ground	1
24	REFCLKP	PECL-I	Reference clock Non-Inverted Input; <b>not in use</b> Internally terminated (100Ohm)	
25	REFCLKN	PECL-I	Reference clock Inverted Input; <b>not in use</b> Internally terminated (100Ohm)	
26	GND		Module Ground	1
27	GND		Module Ground	1
28	TDN	CML-I	Transmitter Inverted Data Input; AC coupled in side the module.	
29	TDP	CML-I	Transmitter Non-Inverted Data Input; AC coupled in side the module.	
30	GND		Module Ground	1

Note

- 1: Module ground pins are isolated from the module case and chassis ground within the module.
- 2: Shall be pulled up with 4.7k to 10k ohm to a voltage between 3.15V and 3.45V on the host board.
- 3: Not connected internally.

## 5. Absolute Maximum Ratings and Recommended Operating Conditions

**Table 5.1. Absolute Maximum Ratings**

Parameter	Symbol	Min	Max	Unit	Note
Storage Temperature	Tst	-40	85	degC	
Relative Humidity (non-condensation)	RH	-	85	%	
Operating Case Temperature	Topc	-5	70	degC	1
Short-term operating case temperature	Top-short	-10	75	degC	2
Supply Voltage	VCC5	-0.3	6.0	V	
Supply Voltage	VCC3	-0.5	3.6	V	
Voltage on LVTTL Input	Vilvttl	-0.5	VCC3+0.5	V	
LVTTL Output Current	Iolvttl	-	15	mA	
Voltage on Open Collector Output	Voco	0	6	V	
Receiver Input Optical Power (Average)	Mip	-	4	dBm	3

Note:

- 1: Ta: -10 to 60degC with 1.5m/s airflow with an additional heat sink. (Reference conditions)
- 2: Performance is not guaranteed. The short term temperature range will not occur continuously, but only during a period of maximum 15 days per year of which 4 days maximum continuously.
- 3: PIN Receiver.

**Table 5.2. Recommended Operating Conditions and Supply Requirements**

Parameter	Symbol	Min	Max	Unit	Note
Operating Case Temperature	Topc	-5	70	degC	
Relative Humidity (non-condensing)	Rhop	-	85	%	
Power Supply Voltage	VCC5	4.75	5.25	V	
Power Supply Voltage	VCC3	3.135	3.465	V	
Power Supply Current	ICC5	-	500	mA	1
Power Supply Current	ICC3	-	750	mA	
Total Power Consumption	Pd	-	3.5	W	

Note:

- 1: The inrush current is included.

## 6. Electrical Interface

### 6.1. High Speed Electrical Interface

#### XFI Application Reference model

Figure 6.1.1. shows the high speed electrical interface (XFI) compliance points.

XFI electrical interface is specified for each compliance point in the chapter 3 of the XFP MSA specification (Rev.4.0).

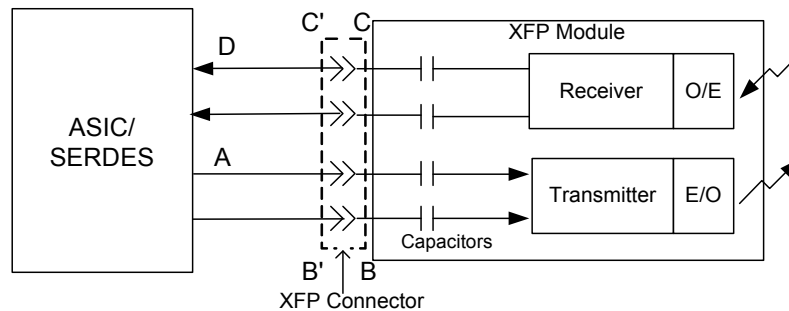

Figure 6.1.1. XFI Application Reference Model

#### XFI Module Transmitter Input Electrical Interface Specification at B'

Table 6.1.1. XFI Transmitter Input Electrical Specification at B'

Parameter -B'	symbol	Min	Typ	Max	Units	Note
Reference differential Input Impedance	Zd	-	100	-	Ohm	
Termination Mismatch	dZm	-		5	%	
Input AC Common mode Voltage				25	mV(RMS)	
Differential Input Return Loss	SDD11	20		-	dB	1
		8		-	dB	2
		See 3		-		3
Common Mode Input Return Loss	SCC11	3		-	dB	4
Differential to Common Mode Conversion	SCD11	10		-	dB	4
Total Input Non-DDJ Jitter	TJtnd	-		0.41	Ulp-p	
Total Input Jitter	TJ	-		0.61	Ulp-p	
Eye Mask	X1	-		0.305	UI	5
	Y1	60		-	mV	
	Y2	-		410	mV	

Note

1: 0.05 to 0.1 GHz

2: 0.1 to 5.5GHz

3: 5.5 to 12GHz,  $SDD11(dB)=8-20.66\log_{10}(f/5.5)$ , with f in GHz

4: 0.1 to 15GHz

5: Eye Mask is defined in Figure 6.1.2.

**XFI Module Receiver Output Electrical Interface Specification at C'**

**Table 6.1.2. XFI Receiver Output Electrical Specification at C'**

Parameter -C'	symbol	Min	Typ	Max	Units	Note
Reference differential Output Impedance	Zd	-	100	-	Ohm	
Termination Mismatch	dZm	-		5	%	
Output AC Common mode Voltage		-		15	mV(RMS)	
Output Rise and Fall time (20%-80%)	trh, tfh	24		-	ps	
Differential Output Return Loss	SDD22	20		-	dB	1
		8		-	dB	2
		See 3		-		3
Common Mode Input Return Loss	SCC22	3		-	dB	4
Deterministic Jitter	TJtnd	-		0.18	Ulp-p	
Total Jitter	TJ	-		0.34	Ulp-p	
Eye Mask	X1	-		0.17	UI	5
	X2	-		0.42	UI	
	Y1	170		-	mV	
	Y2	-		425	mV	

Note

1: 0.05 to 0.1 GHz

2: 0.1 to 5.5GHz

3: 5.5 to 12GHz,  $SDD11(dB)=8-20.66\log_{10}(f/5.5)$ , with f in GHz

4: 0.1 to 15GHz

5: Eye Mask is defined in Figure 6.1.3.

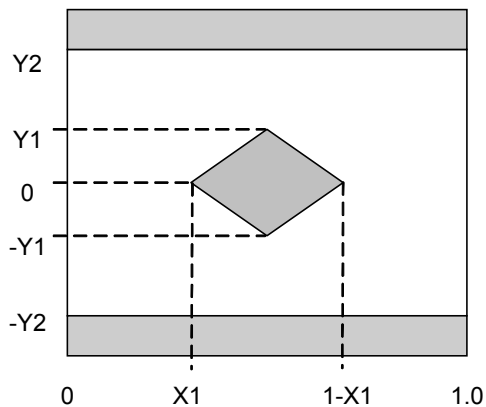

**Figure 6.1.2.**  
**Transmitter Input Eye Mask**

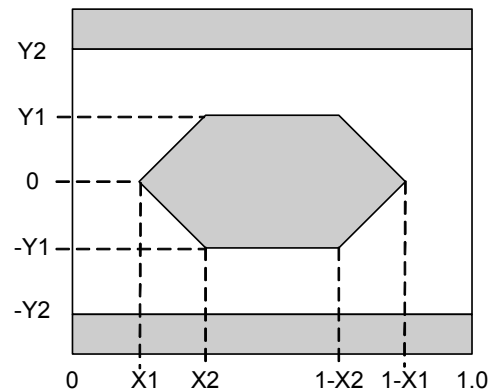

**Figure 6.1.3.**  
**Receiver Output Eye Mask**

## XFI Reference Clock Specification

Note that the reference clock is not needed for SXP3101EX-03. The differential reference clock signals if used are internally terminated across 100Ohm as shown in Figure 2.1.

## 6.2. CDR Specification

### Transmitter CDR

Table 6.2.1. Transmitter CDR Specification

Parameter	symbol	Min	Typ	Max	Units	Note
Jitter Transfer Bandwidth	BW	-		6	MHz	1
Jitter Transfer Peaking	-	-		1	dB	2

Note

- 1: PRBS<sup>2^31-1</sup> Data or Scrambled 64B/66B
- 2: Frequency > 50kHz

### Receiver CDR

Table 6.2.2. Receiver CDR specification

Parameter	symbol	Min	Typ	Max	Units	Note
Jitter Transfer Bandwidth	BW	-		12	MHz	1
Jitter Transfer Peaking	-	-		1	dB	2

Note

- 1: PRBS<sup>2^31-1</sup> Data or Scrambled 64B/66B
- 2: Frequency > 50kHz

### 6.3. Low Speed Electrical Interface

Table 6.3.1. Low Speed Control and Alarm Signals Electrical Interface

Parameter	Symbol	Min.	Typ.	Max.	Units	Note
XFP Interrupt, Mod_NR, RX_LOS	V <sub>ol</sub>	0		0.4	V	1
	V <sub>oh</sub>	V <sub>cc</sub> -0.5		V <sub>cc</sub> +0.3		2
XFP TX_DIS, P_DOWN/RST	V <sub>il</sub>	-0.3		0.8	V	3
	V <sub>ih</sub>	2		V <sub>cc3</sub> +0.3		4
XFP SCL and SDA Output	V <sub>ol</sub>	0		0.4	V	1
	V <sub>oh</sub>	V <sub>cc</sub> -0.5		V <sub>cc</sub> +0.3		2
XFP SCL and SDA Input	V <sub>il</sub>	-0.3		V <sub>cc3</sub> +0.3	V	5
	V <sub>ih</sub>	V <sub>cc3</sub> -0.7		V <sub>cc3</sub> +0.5		6
Capacitance for XFP SCL and SDA I/O pin	C <sub>i</sub>	-		14	pF	
Total bus capacitance load for SCL and SDA	C <sub>b</sub>	-		100	pF	7
		-		400	pF	8

Note

- 1: Pull-up resistor must be connected to host\_Vcc on the host board. I<sub>ol</sub>(max)=3mA
- 2: Pull-up resistor must be connected to host\_Vcc on the host board.
- 3: Pull-up resistor connected to VCC3 within XFP module. I<sub>il</sub>(max)= -10μA.
- 4: Pull-up resistor connected to VCC3 within XFP module. I<sub>ih</sub>(max)= 10μA.
- 5: Pull-up resistor must be connected to host\_Vcc on the host board. I<sub>ol</sub>(max)= -10μA.
- 6: Pull-up resistor must be connected to host\_Vcc on the host board. I<sub>ol</sub>(max)= 10μA.
- 7: at 400KHz, 3.0kohms, at 100kHz 8.0kohms max.
- 8: at 400KHz, 0.8kohms, at 100kHz 2.0kohms max.

## 7. Optical Interface

Table 7.1. Optical Interface

Transmitter Optical Interface						
Parameter	Symbol	Min	Typical	Max	Unit	Note
Operating Data Rate	-		9.95328 10.3125		Gb/s	1 2
Data rate tolerance	-		+/-20 +/-100		ppm	1 2
Output Center Wavelength	l <sub>tc</sub>	1530		1565	nm	
SMSR	SMSR	30		-	dB	
Average Output Power	P <sub>o</sub>	-4.7		4.0	dBm	3
Disabled Power	P <sub>off</sub>			-30	dBm	
Extinction Ratio	ER	3.0		-	dB	3
Optical Modulation Amplitude	OMA	-1.7		-	dBm	
Transmitter and Dispersion Penalty	TDP	-		3.0	dB	
OMA-TDP	OMAt <sub>dp</sub>	-2.1		-	dBm	
Optical Return Loss Tolerance	-			21	dB	
Eye Mask {X1, X2, X3, Y1, Y2, Y3}	-	{0.25, 0.40, 0.45, 0.25, 0.28, 0.40}				4
RIN <sub>21</sub> OMA	RIN			-128	dB/Hz	
Receiver Optical Interface						
Parameter	Symbol	Min	Typical	Max	Unit	Note
Operating Data Rate	-		9.95328 10.3125		Gb/s	1 2
Data rate tolerance	-		+/-20 +/-100		ppm	1 2
Input Center Wavelength	l <sub>rc</sub>	1260		1565	nm	
Overload	R <sub>ovl</sub>	-1.0		-	dBm	
Sensitivity in OMA	OMA <sub>0</sub>	-		-14.1	dBm	3
Stressed Sensitivity in OMA	OMA <sub>st</sub>	-		-11.3	dBm	
RX_LOS Assert Level	RLOS <sub>a</sub>	-30		-25	dBm	
RX_LOS Deassert Level	RLOS <sub>d</sub>	-		-22	dBm	
RX_LOS Hysteresis	RLOS <sub>h</sub>	1		5	dB	
Optical Return Loss	ORL	-		-26	dB	

Note1: 10GBASE-EW

Note2: 10GBASE-ER

Note3: Measured at 10.3125Gbps, Non-framed PRBS2<sup>31</sup>-1, NRZ

Note4: Refer to Fig.7.1.

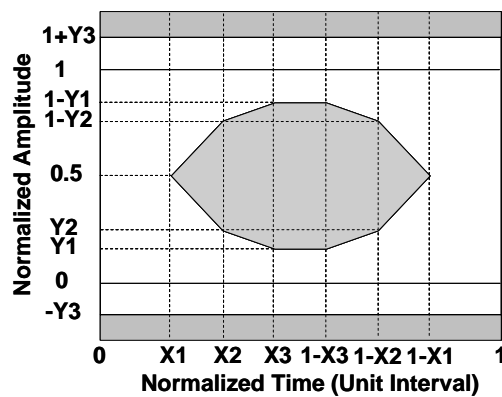

Figure.7.1. Transmission eye mask definition

## 8. Electrical and Optical I/O Signal Relationship

Table.8.1. TX\_DIS vs. Optical Output Power

TX_DIS	Optical Output Power
Low ( $V_{IL} = -0.3$ to $0.8V$ )	Enabled
High ( $V_{IH} = 2.0$ to $VCC3+0.3V$ )	Disabled ( $<-30dBm$ )

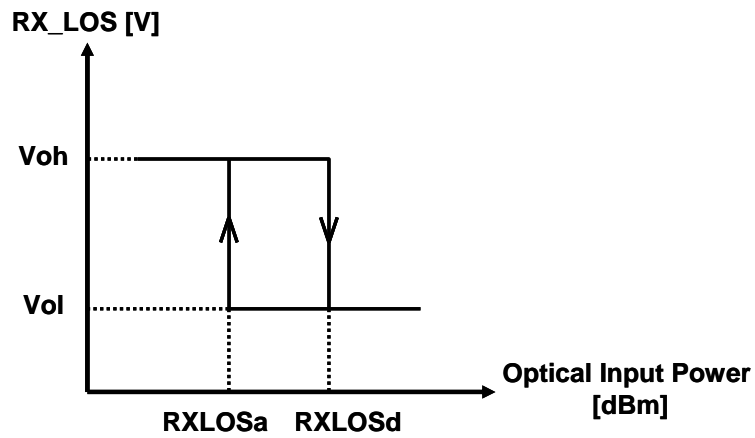

Figure.8.1. Optical Input Power vs. RX\_LOS

## 9. User Interface

### 9.1. XFP Mechanical Interface

XFP Mechanical Interface is specified in the chapter 6 in the XFP MSA specification.

#### XFP Mechanical Components

Figure 9.1.1. shows the XFP transceiver concept and mechanical components.

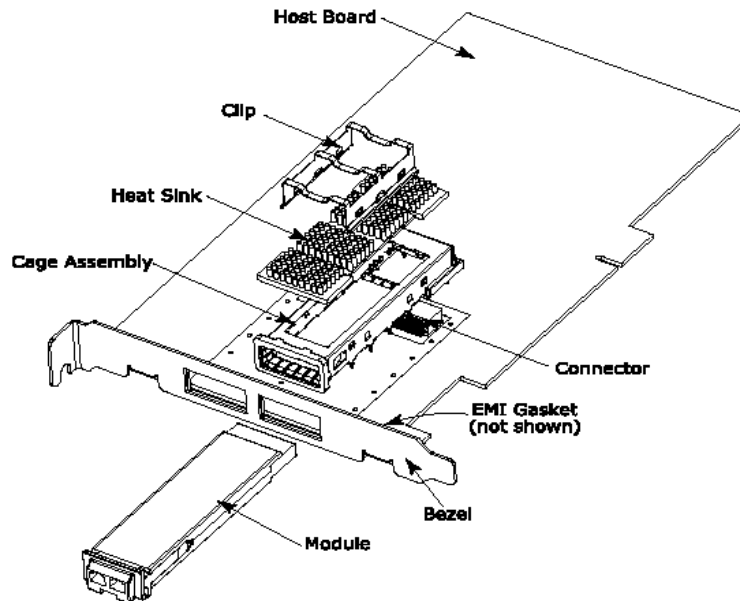

Figure 9.1.1. XFP Mechanical Interface Concept and Components

#### XFP Host board Mechanical Layout

XFP Host Board Layout is specified in the Figure 35 of the XFP MSA specification (Rev. 4.0).

#### Host Board XFP Connector Footprint and Layout

Host board XFP connector layout is specified in the Figure 36 of the XFP MSA Specification (Rev. 4.0).

#### XFP Datum Alignment and Bezel Design

XFP datum alignment (depth) is specified in the Figure 30 of the XFP MSA specification (Rev. 4.0).

The recommended bezel design is specified in the Figure 37 of the XFP MSA specification (Rev. 4.0).

#### XFP Connector and XFP Cage Assembly

The XFP 30-contact connector mechanical specification is shown in Figure 39 of the XFP MSA specification (Rev. 4.0)

The XFP Cage Assembly mechanical specification is shown in the Figure 41 of the XFP MSA specification (Rev. 4.0).

## 9.2. Management Interface

### XFP 2-Wire Serial Interface Protocol

XFP 2-wire serial interface is specified in the Chapter 4 of the XFP MSA specification.

The XFP 2-wire serial interface is used for serial ID, digital diagnostics, and certain control functions. The 2-wire serial interface is mandatory for all XFP modules.

The 2-wire serial interface address of the XFP module is 1010000X(A0h). In order to access to multiple modules on the same 2-wire serial bus, the XFP has a MOD\_DESEL (module deselect pin). This pin (which is pull high or deselected in the module) must be held low by the host to select of interest and allow communication over 2-wire serial interface. The module must not respond to or accept 2-wire serial bus instructions unless it is selected.

### XFP Management Interface

XFP Managed interface is specified in the Chapter 5 of the XFP MSA specification.

The Figure 9.2.2. shows the structure of the memory map. The normal 256 Byte address space is divided into lower and upper blocks of 128 Bytes. The lower block of 128 Byte is always directly available and is used for the diagnostics and control functions that must be accessed repeatedly. Multiple blocks of memories are available in the upper 128 Bytes of the address space. These are individually addressed through a table select Byte which the user enters into a location in the lower address space. The upper address space tables are used for less frequently accessed functions and control space for future standards definition.

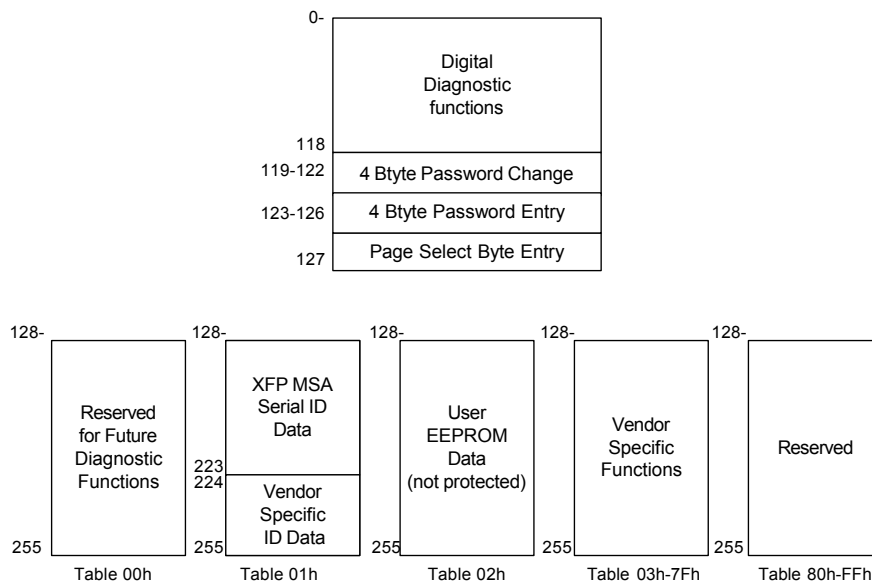

**Figure 9.2. 2-wire Serial Interface Memory Map**

### 9.3. A/D Accuracy and Values

**Table 9.3.1. A/D Accuracy**

Data Address	Parameter	Accuracy	Relative accuracy	Units Display	Note
96-97	Temperature	+/-3degC	NA	Signed 2's complement integer degC	Junction temperature of monitoring IC.
98-99	Reserved				
100-101	Tx Bias	+/-10%	NA	×2μA	Specified by nominal value
102-103	Tx Power	+/-2dB@BOL (Note1) (Range: -1 to +2dBm)	+/-1dB (Note2)	×0.1μW	Average Power
104-105	Rx Power	+/-2dB@BOL (Note1) (Range: -16 to +2dBm)	+/-1dB (Note2)	×0.1μW	At specified transmitter wavelength.
106-107	Vcc3	+/-3%	NA	×100μV	3.3V Only

**Table 9.3.2. A/D Values**

Byte	Bit	Name	Description
96	All	Temperature MSB	Signed 2's complement integer temperature (-40 to +125degC) based on internal temperature measurement
97	All	Temperature LSB	Fractional part of temperature(count/256)
98-99	All		Reserved
100	All	Tx Bias MSB	Measured Laser Bias Current in mA. Bias current is full 16 bit value *2μA. (Full range of 0 to 131mA)
101	All	Tx Bias LSB	
102	All	Tx Power MSB	Measured Tx output power in mW. Tx power is full 16 bit value *0.1μW. (Full range of -40 to +8.2dBm)
103	All	Tx Power LSB	
104	All	Rx Power MSB	Measured Rx input power in mW. Tx power is full 16 bit value *0.1μW. (Full range of -40 to +8.2dBm)
105	All	Rx Power LSB	
106	All	Vcc3 MSB	Internally measured transceiver supply voltage. Vcc is full 16 bit value*100μV. (Full range of 0 to +6.55 Volts)
107	All	Vcc3 LSB	
108	All	AUX 2 MSB	TBD
109	All	AUX 2 LSB	

Note1. Over specified temperature and voltage.

Note2. Over specified temperature and voltage range over the life of the product into a fixed measurement system.

### 9.4. Serial ID Memory Map (Data Field – Page 01h)

Address	Size (Bytes)	Name	Hex	ASC	Description	Address	Size (Bytes)	Name	Hex	ASC	Description		
<b>Base ID Filed</b>						<b>Extended ID Field</b>							
128	1	Identifier	06		XFP module	192	4	Power Supply	AF		3.5W		
129	1	Ext. Identifier	90		3.5W Max With CDR	193			96	1.5W (Note3)			
130	1	Connector	07		LC Connector	194			A8	500mA/800mA @ +5.0V / +3.3V			
131	8	Tranciver	22		10GBASE-ER / EW	195			00	(Note4)			
132			00			196							
133			00			197							
134			00			198							
135			00			199							
136			00			200							
137			00			201							
138			00			202							
139	1	Encoding	90		64B/66B, NRZ	203	16	Vendor SN	Note5				
140	1	BR-Min	64		9.95Gbps	204							
141	1	BR-Max	6C		10.75Gbps	205							
142	1	Length (SMF)-km	28		40km	206							
143	1	Length (E-50 μm)	00			207							
144	1	Length (50 μm)	00			208							
145	1	Length (62.5 μm)	00			209							
146	1	Length (Copper)	00			210							
147	1	Device Tech	74		1550nm EML, PIN Detector	211							
148	16	Vendor name	53	S		212			8	Date Code & Lot Code	Note6		Year
149			75	u		213						Month	
150			6D	m		214						Day	
151			69	i		215						Lot	
152			74	t		216							
153			6F	o		217							
154			6D	m		218							
155			6F	o		219							
156			45	E		220	1	Diagnostic Monitoring Type	08		No BER Support		
157			6C	l		221	1	Enhanced Options	60		Average Power		
158			65	e		222	1	Aux Monitoring	70		Optional Soft TX Disable		
159			63	c		223	1	CC EXT	Note7		Optional Soft P down		
160			74	t		224	<b>Vendor Specific ID Fileds</b>						
161			72	r		225	32	Vendor Specific					
162			69	i		226							
163			63	c		227							
164	1	CDR Support	F0		228								
165	3	Vendor OUI	00			229							
166			00			230							
167			5F			231							
168			53	S		232							
169			58	X		233							
170			50	P		234							
171			33	3		235							
172			31	1		236							
173			30	0		237							
174			31	1		238							
175			45	E		239							
176			58	X		240							
177			2D	-		241							
178			30	0		242							
179			33	3		243							
180			20			244							
181	20			245									
182	20			246									
183	20			247									
184	2	Vendor rev	41 to 5A	A to Z									
185	20												
186	2	Wavelength	79		1550nm @ RT								
187	18												
188	2	Wavelength Tolerance	0F		+/-20nm (Note1)								
189	A0												
190	1	Max Case Temp	46		70degC								
191	1	CC BASE	Note2										

Note1. The guaranteed +/- range of transmitter output wavelength under all normal operating conditions.

Note2. Address 191 is check sum of bytes 128 to 190.

Note3. Maximum total power dissipation in power down mode.

Note4. +1.8V/-5.2V is not in use.

Note5. Address 196 to 211 Vendor Serial Number.

Note6. Address 212 to 219 Date code.

Note7. Address 223 is check sum of bytes 192 to 222.

### 9.5. Supply filter

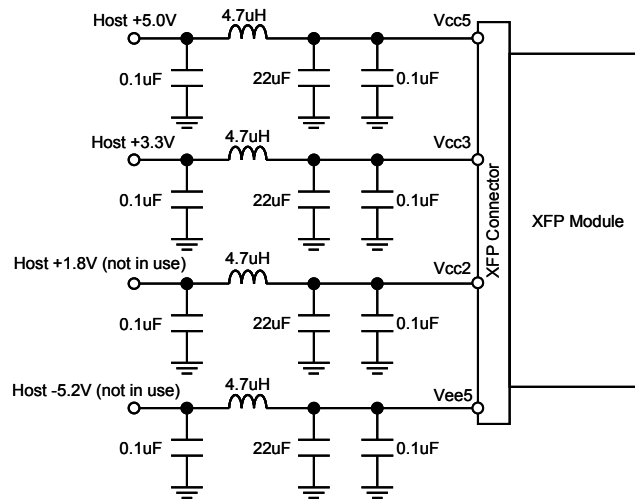

Figure 9.5. Supply Filter

### 9.6. Recommended Electrical Interface

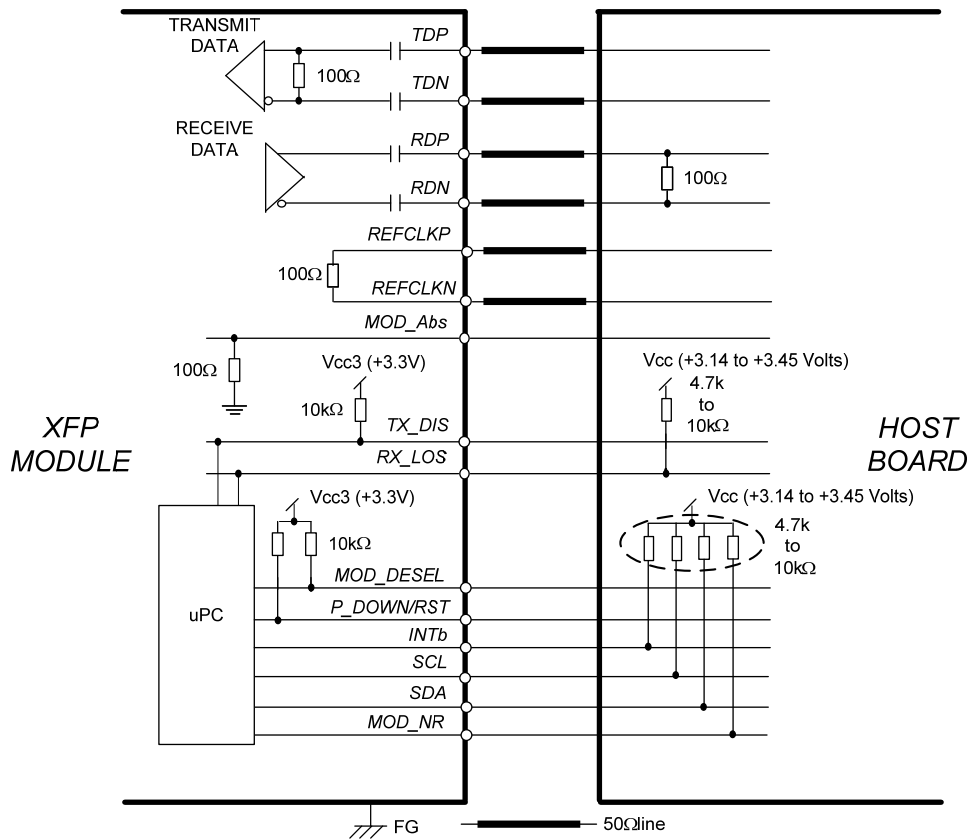

Figure 9.6. Recommended Electrical Interface

## 10. Qualification Testing

SXP3101EX-03 10Gb/s transceiver is qualified to Sumitomo Electric Industries internal design and manufacturing standards. Telecordia GR-468-CORE reliability test standards, using methods per MIL-STD-883 for mechanical integrity, endurance, moisture, flammability and ESD thresholds, are followed.

## 11. Laser Safety Information

SXP3101EX-03 OC-192 transceiver uses a semiconductor laser system that is classified as Class 1 laser products per the Laser Safety requirements of FDA/CDRH, 21 CFR1040.10 and 1040.11. These products have also been tested and certified as Class 1 laser products per IEC 60825-1:2001 International standards.

---

### Caution

---

If this product is used under conditions not recommended in the specification or is used with unauthorized revision, the classification for laser product safety is invalid. Reclassify the product at your responsibility and take appropriate safety measures.

---

## 12. Electromagnetic Compatibility (Pending)

### EMI (Emission)

SXP3101EX-03 is designed to meet FCC Class B limits for emissions and noise immunity per CENELEC EN50 081 and 082 specifications.

### RF Immunity

SXP3101EX-03 has an immunity to operate when tested in accordance with IEC 61000-4-3 (80- 1000MHz, Test Level 3) and GR-1089.

### Electrostatic Discharge (ESD) Immunity

SXP3101EX-03 has an immunity against direct and indirect ESD when tested accordance with IEC 61000-4-2.

### 13. RoHS COMPLIANCE (Using the NIE Exemption for Lead in Solders)

Compliance versus requirements contained within the following reference document is guaranteed: “Directive 2002/95/EC of the European Parliament and of the Council of 27 January 2003 on the restriction of the use of certain hazardous substances in electrical and electronic equipment” (RoHS Directive)”. This product is compliant at the RoHS-5 level, requiring the NIE Exemption for lead contained in solders.

### 14. Ordering Information

#### 14.1. Part Numbering System

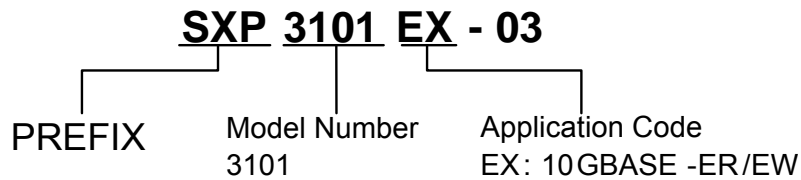

#### 14.2. Evaluation Board Kit

For test purposes, Evaluation Board model number SK3101A and SP3101A may be ordered to use with the SXP3101 Series transceivers.

SK3101A : SXP3101 XFP evaluation board

SP3101A : XFP 2-wire serial interface evaluation kit

#### 14.3. Ordering Number Code

Table 13. SXP3101 Application Code

P/N	Distance	Fiber	E/O	O/E	ITU-T G691	Telecordia GR-253	IEEE 802.3ae
SXP3101EX-03	40km	STD-SMF	1.55um EML	PIN	-	-	10GBASE- ER/EW

#### **14.4. Firmware version**

This product contains the firmware inside. Sumitomo Electric may upgrade the firmware version without advance notice as far as such would be upper compatible. When customer should prefer to have the current firmware version, Sumitomo Electric will accommodate such request and will assign customized part number for this purpose.

#### **14.5. I2C Interface**

If the serial clock(SCL) is more than 100kHz, the SCL is held in line low(clock stretching) during an I2C read or write operation.

### **15. Contact Information**

#### **U.S.A.**

ExceLight Communications, 4021 Stirrup Creek Drive, Suite 200 Durham, NC 27703

Tel. +1-919-361-1600 / Fax. +1-919-361-1619

E-mail: [info@excelight.com](mailto:info@excelight.com)

<http://www.excelight.com>

#### **Europe**

Sumitomo Electric Europe Ltd., 220, Centennial Park, Elstree, Herts, WD6 3SL, United Kingdom

Tel. +44-208-953-8681

Fax. +44-208-207-5950

E-mail: [photonics@sumielectric.com](mailto:photonics@sumielectric.com)

<http://www.sumielectric.com>

#### **Japan**

Sumitomo Electric Industries, Ltd.

1, Taya-cho, Sakae-ku, Yokohama, 244-8588

Tel. +81-45-853-7154 / Fax. +81-45-851-1932

E-mail: [product-info@ppd.sei.co.jp](mailto:product-info@ppd.sei.co.jp)

[http://www.sei.co.jp/Electro-optic/index\\_e.html](http://www.sei.co.jp/Electro-optic/index_e.html)